

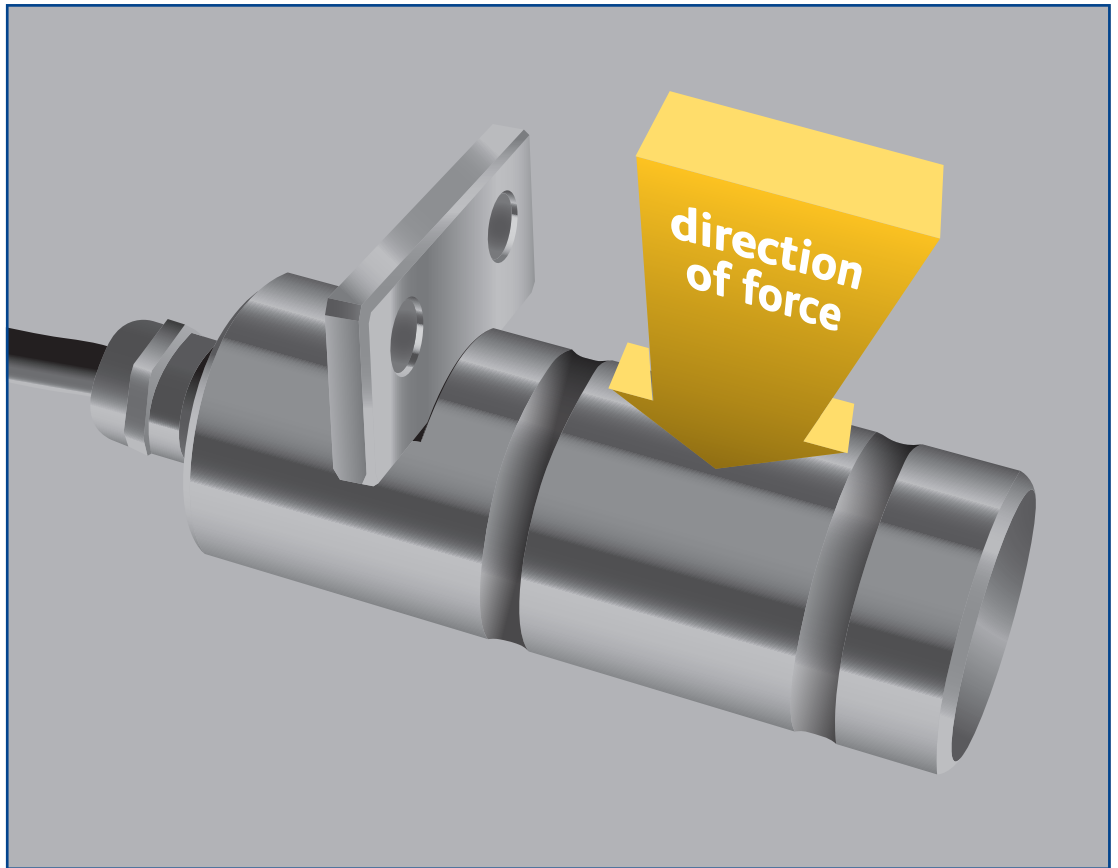

load pin



The Straightpoint range of Load Measurement Pins are designed for general use. They are machined from high tensile stainless steel and are normally supplied complete with an anti-rotation plate.

They are built to exacting standards and are suitable for use in exposed situations and can be supplied to withstand immersion in seawater. This range of load cells is proof loaded to 150% of the normal rated load.



Requires connection to our Handheld Plus (SU3343), our desktop controller data logging software package (DCP10M) or our External Amplifier (SA-3420), or other instrumentation.

Please advise cable configuration on order - Radial or Axial Pin exit.
If you require a load pin to a particular size and design, download our load pin questionnaire, found on our website, and return, price on application.

Applications:

- Marine tankers, offshore platforms
- Elevator and floor conveyor testing and certification
- Bearing blocks, pivots and shackles
- Cable laying equipment
- Rope, chain, and brake anchors
- Bridge support cables
- Mooring lines
- Pulleys and sheaves
- Crane cables
- Hoisting gear
- Winches

metric specifications

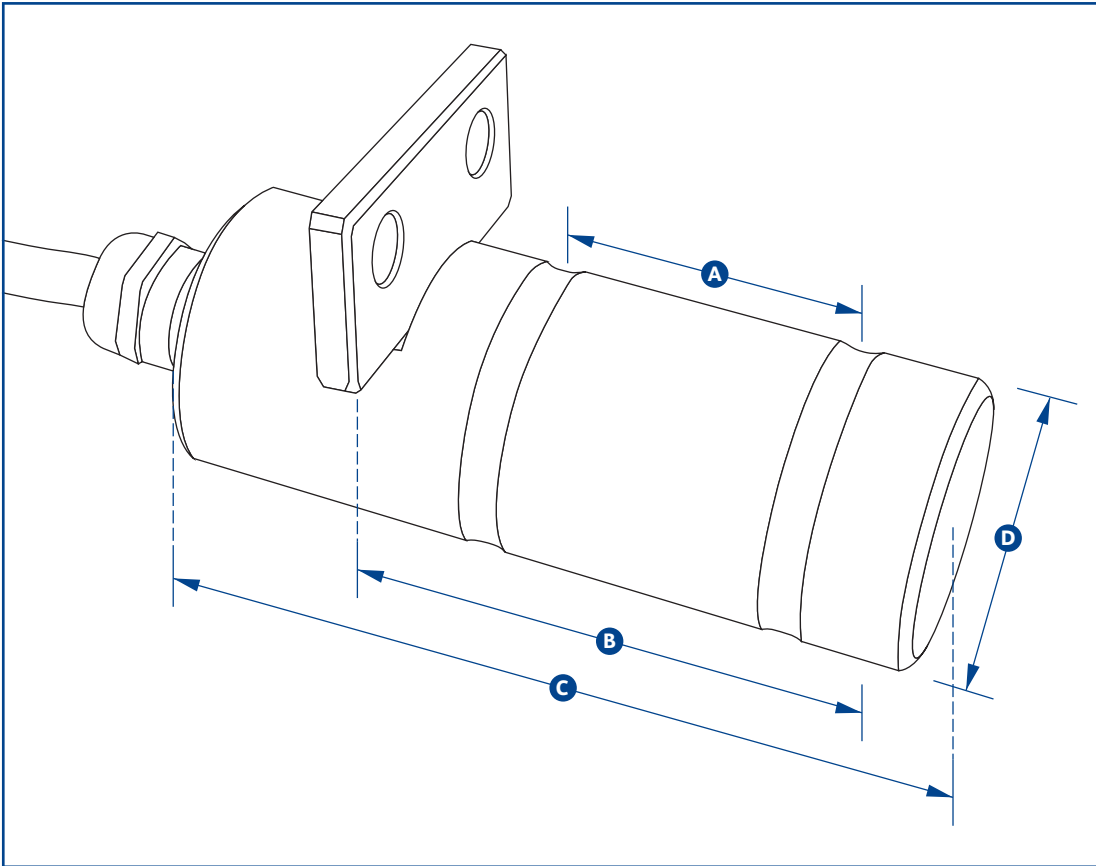

load pin

Part Number	LP500KG	LP1T	LP2.5T	LP3.5T	LP6.5T	LP15T	LP25T	LP50T	LP100T	LP250T	LP500T	LP750T	LP1000T	LP1500T
Capacity	500kg	1000kg	2.5te	3.5te	6.5te	15te	25te	50te	100te	250te	500te	750te	1000te	1500te
Resolution	0.2kg	0.5kg	0.001te	0.001te	0.002te	0.002te	0.005te	0.01te	0.05te	0.1te	0.2te	0.2te	0.5te	0.5te
Units	kgs, tonnes													
Weight	0.9kg	1kg	1.2kg	1.4kg	2kg	3.1kg	5.6kg	8.6kg	11.8kg	29.8kg	79.2kg	146kg	275kg	389kg
Safety Factor	300% of SWL													
Operating Temp	-20°C to +70°C													
Accuracy	±1% of applied load													
Protection	IP67 (IP68 available as option)													
Dimension A	24	35	45	50	63	75	89	102	110	130	225	295	360	430
Dimension B	36	49	70	75	95	114	152	178	190	220	370	500	612	731
Dimension C	70	80	100	105	125	150	195	225	230	300	440	590	712	832
Dimension D	20	20	25	30	40	50	63	75	88	125	170	200	250	275

Please note: If you require a load pin to a particular size and design, download our load pin questionnaire and return (price on application).
Wireless Load Pins available (price on application).