



Crosby | **SP**[®]

**Load
Monitoring**

Company Profile



Since 1976 Crosby Straightpoint's world-class, solution-based systems have been at the forefront of industrial weighing and load monitoring technology. Now a part of the Crosby Group, the largest manufacturers of rigging and lifting equipment globally, the symbiosis is seamless and has only enhanced what we can offer customers.

With UK, USA and Belgium headquarters and a global dealer network, the simple to use, cost-effective product range has enhanced safety for engineers and rigging professionals worldwide for over 45 years. The engineering team design and manufacture a broad spectrum of first-class load monitoring systems to capabilities more than 1,500 tonnes to include:

- Tension 'Link' load cells
- Cable and synthetic rope tensionmeters
- Shackle load cells
- Dynamometers
- Crane scales
- Compression load cells
- Load pins
- ATEX/IECEX options
- Bluetooth options
- Custom made load cells
- Software solutions

Crosby Straightpoint wireless Windows-based software, and full line of accessories allow for the simple and easy acquisition an analysis of force and load monitoring data.

Continuously producing and adding industry leading innovations to their product catalogue; Crosby Straightpoint provide lifting and rigging professionals with the pinnacle in solutions for lifting projects.

Such recent innovations include the introduction of the HHP App (iOS/Android). The accompanying Bluetooth wireless telemetry load cell product range, along with the latest connectivity technology, help combine it to become a highly effective remote monitoring tool.

All Crosby Straightpoint products are fully tested, in stock and available on fast lead times. They are despatched in an aluminium flight case (or wooden crate for large capacities) with full documentation, including multi-lingual manuals, certification of calibration, proof test and CE conformity. All products also come with a 2-year back to base warranty certificate to reflect the confidence they have in what they provide.

- Onshore and offshore Wind Energy
- Shipping and marine
- Mining
- Transport
- Health and safety
- Entertainment
- Crane and rigging
- Salvage and decommissioning
- Oil and gas
- Construction
- Power generation
- Utilities
- Topsides
- Break bulk
- Military

Crosby Straightpoint's highly qualified team of product specialists are available to assist with any application, and its global network of first-class distributors ensure that wherever your location is, an approved Straightpoint dealer is close by.

Crosby Straightpoint's continued investment in research and development enables them to remain at the forefront of technological development with the world-leading products and performance to meet their customers' demands.

With hundreds of units always in stock, Crosby Straightpoint aim to deliver any standard product up to capacities in excess of 1,500 tonnes anywhere in the world – FAST!

Page	Part	Description
02-03	RLP	Radiolink plus
04-05	WLS	Wireless LoadShackle
06-07	BLD & SID	6.5t Dynamometer
08-09	WNITC	LoadSafe Compression
10-11	COLT	Clamp On Line Tensionmeter
12-13	BOLT	Bolt In Line Tensionmeter
14-15	CableSafe	CableSafe
16-17	TIMH	Running Line Dynamometer
18-19	TowCell	Wireless Towbar Loadcell
20-21	CS	Wireless Chain Loadcell
22-23	INSIGHT	Software
24-25	LoadConnect	Cloud based software
26-27	HHP App	Wireless Accessories / HHP App
28-29	HHP	HHP / Accessories
30-31	SL	Subsea Loadcell
32-33	LLP	Loadlink plus
34-35	WLP	Wirelink plus
36-37	SLB	Cabled Loadshackle
38-39	NITC	Cabled Compression
40-41	LP	Loadpin
42-43	LBP	Loadblock plus
44-45	MWP	Miniweigher plus
46-47	...	Accreditations / Industries

Accreditations

Crosby Straightpoint is an ISO9001:2015 approved company (registration number FM 584438) audited by the British Standards Institute (BSI) who are a notified UKAS body.

Straightpoint's hazardous area products are verified by CSA, notification No: SIRA 15 ATEX M725

Members of key associations such as LEEA (Lifting Equipment Engineers Association), AWRF (American Wire Rope Fabricators) and SC&RA (Specialized Carriers & Rigging Association).

Several key personnel are members of ASME (American Society of Mechanical Engineers).



Warranty

All Crosby Straightpoint products ship with a two year back to base warranty as standard.

Global Distribution

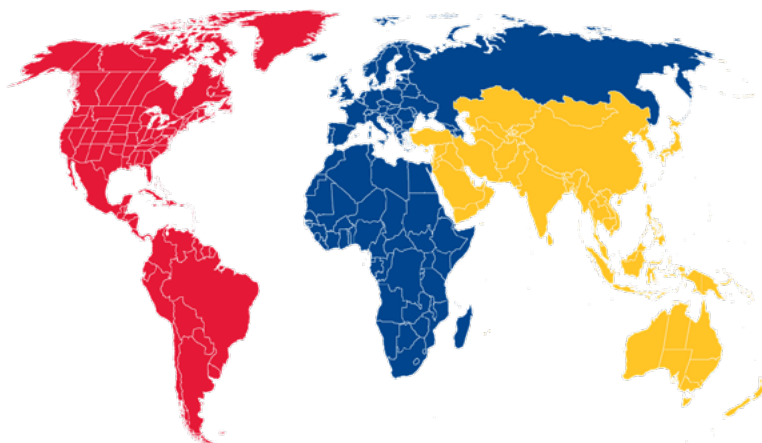

Contact Details

123 Proxima Park
 Houghton Avenue
 Waterlooville, Hampshire
 PO7 3DU · UK
 Tel: +44 (0)2392 484491

Industriepark B26
 2220 Heist-op-den-Berg
 Belgium
 Tel: 0032 15 75 71 25

2801 Dawson Road
 Tulsa, OK 74110 · USA
 Tel: +1 (918) 834-4611



Radiolink plus



- Hardened bushes to accept industry standard shackles
- Std. AA Batteries 1200hrs Easy no tools access
- Internal Antennae
- Environmental protection IP67 or NEMA6
- High-quality hard anodised aerospace aluminium
- Angular ends to reduce weight and snagging when rigged

Radiolink plus is designed to be rigged with Crosby standard shackles - DNV-GL type approved wireless tension load cell capable of weighing and dynamic load monitoring in capacities from 1t to 500t – from stock with an ATEX and IECEx version available for hazardous areas, zones 0, 1 & 2.

Two versions of the RLP are available:

- Long range 2.4GHz version providing industry-leading wireless range of 1000m or 3280ft to SP's SW-HHP handheld or software options.
- Bluetooth output and can be connected to any smart phone running our free HHP app on iOS or Android, at ranges up to 100m or 328ft.

Constructed from high-quality aerospace grade aluminium, the RLP features an advanced internal design structure. This design provides the product with an unrivalled strength to weight ratio. The use of a separate internal sealed enclosure administers the load cell's electronic components with IP67 or NEMA6 environmental protection, even with the battery cover plate missing. All these features makes it an industry-leading dynamometer, suitable for use in the harshest of environments.

The versatile RLP is able to provide an update rate of 3Hz and can be easily configured to run at industry-leading speeds of up to 200Hz, making it ideal for dynamic force measurement.



- 1000m or 3280ft Wireless Range
- Reads up 4 load cells simultaneously
- Low Battery Signal Strength
- 90db Audible Overload Alarm
- Multiple Display Units t/lbs/kg/kN
- 200Hz Peak Hold
- Tare

Decades of development into this product include many stand out features such as SP's unique strain gauging method that helps compensate for wire rope torque when the Radiolink is loaded. The Radiolink plus tension load cell can also be used in combination with Crosby|Straightpoint 'INSIGHT' high speed wireless data logging software allowing for simultaneous control, display and real time data logging of up to 126 Crosby|Straightpoint wireless load cells.

A full array of wireless accessories are also available including wireless score board, overload alarm and base station with analogue (4-20mA) or 2 relay or RS485 ASCII outputs.

FEATURES AND BENEFITS

- Proprietary 2.4 GHz Wireless
- Remote On-Off from handheld display or software
- ATEX Zones 0, 1 & 2 available
- Design validated by F.E.A.
- 2-year warranty
- DNV-GL Type Approval
- Complies with ASME B30.26
- Bluetooth option is available and is supplied with a free HHP App for iOS and Android See page 27

Accessories available for the handheld:

Wall or Cab Mount Bracket
SP Crosby Part Nos. SU3282 2789228

Rugged Rubber Boot
SP Crosby Part Nos. SU4045 2789232

Also available with hazardous area approval. Zones 0, 1 & 2



ATEX / IECEX
Ex ia IIC T4 Ga

Certification numbers:
RLP ATEX

IECEX SIR 15.0071X / SIR A 15ATEX2195X / CSAE 22UKEX1267X

SW-HHP ATEX

IECEX SIR 15.0072X / SIR A 15ATEX2196X / CSAE 22UKEX1267X

Add 'ATEX' to the part number when ordering ATEX/IECEX products. For example: RLP6T5-ATEX

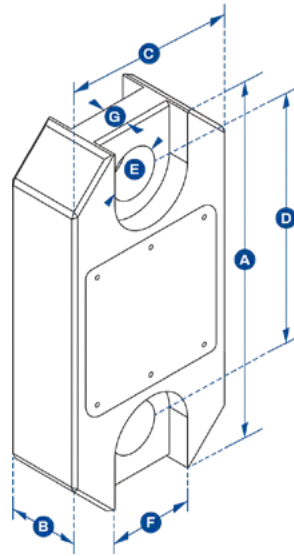

SP Model	RLP1T	RLP2T5	RLP6T5	RLP12T	RLP25T	RLP35T	RLP55T	RLP75T	RLP100T	RLP150T	RLP200T	RLP250T	RLP300T	RLP500T
Crosby part	2789084	2789089	2789094	2789082	2789088	2789091	2789093	2789095	2789081	2789083	2789085	2789087	2789090	2789092
Capacity	1,000 kg	2.5 te	6.5 te	12 te	25 te	35 te	55 te	75 te	100 te	150 te	200 te	250 te	300 te	500 te
	2,200 lb	5,500 lb	14,300 lb	26,000 lb	55,000 lb	77,000 lb	120,000 lb	165,000 lb	220,000 lb	330,000 lb	440,000 lb	550,000 lb	660,000 lb	1,100,000 lb
Resolution	0.5 kg	0.001 te	0.001 te	0.002te	0.005 te	0.005 te	0.01 te	0.01 te	0.05 te	0.05 te	0.1 te	0.1 te	0.1 te	0.1 te
	1 lb	2 lb	2 lb	5 lb	10 lb	10 lb	20 lb	20 lb	100 lb	100 lb	200 lb	200 lb	200 lb	200 lb
Units	kg	te	te	te	te	te	te	te	te	te	te	te	te	te
	lb	lb	lb	lb	lb	lb	lb	lb	lb	lb	lb	lb	lb	lb
Weight	1.5 kg	1.5 kg	2.4 kg	3.7 kg	5 kg	8.6 kg	13 kg	16 kg	34 kg	46 kg	82 kg	82 kg	118 kg	280 kg
	3.3 lb	3.3 lb	5.3 lb	8.2 lb	11 lb	19 lb	28.7 lb	35.3 lb	75 lb	101.4 lb	180.8 lb	180.8 lb	260 lb	617 lbs
Safety Factor	12.1	7:1	7:1	7:1	5:1	5:1	5:1	5:1	5:1	4:1	5:1	4:1	5:1	5:1
Battery Type	Handheld - 2 x AA / Loadcell 4 x AA													
Battery Life	Handheld - 40 hrs / Loadcell 1,200 hrs continuous (Loadcell 500 hrs if Bluetooth)													
Display Type	240x128 multi-line dot matrix with backlight													
Operating Temp	-10 to +50 °C / 14 to 122°F													
Accuracy	±0.1% full scale													
Frequency	2.4GHz													
Range (Max)	1,000 metres / 3,280 feet (100 m / 328 ft if Bluetooth)													
Data Rate	3Hz - up to 200Hz can be ordered for dynamic load monitoring applications													
Protection	IP67													
	NEMA6													
Dimension A	204	204	249	305	340	393	424	470	608	670	700	700	806	1050
	8.03"	8.03"	9.80"	12.01"	13.39"	15.47"	16.69"	18.50"	23.94"	26.38"	27.56"	27.56"	31.73"	41.33"
Dimension B	43	43	43	47	60	75	75	75	99	99	144	144	150	185
	1.69"	1.69"	1.69"	1.85"	2.36"	2.95"	2.95"	2.95"	3.90"	3.90"	5.67"	5.67"	5.91"	7.29"
Dimension C	104	104	113	113	115	126	180	202	255	303	350	350	426	570
	4.09"	4.09"	4.45"	4.45"	4.53"	4.96"	7.09"	7.95"	10.04"	11.93"	13.78"	13.78"	16.77"	22.44"
Dimension D	146	146	165	193	215	225	230	260	320	360	350	350	350	450
	5.75"	5.75"	6.50"	7.60"	8.46"	8.86"	9.06"	10.24"	12.60"	14.17"	13.78"	13.78"	13.78"	17.72"
Dimension ØE	24.5	24.5	38	47.5	55	60	76	76	109	109	145	145	160	200
	0.96"	0.96"	1.50"	1.87"	2.17"	2.36"	2.99"	2.99"	4.29"	4.29"	5.71"	5.71"	6.30"	7.87"
Dimension F	48	48	65	Not relevant in this capacity										
	1.89"	1.89"	2.60"											
Dimension G	19	19	32	Not relevant in this capacity										
	0.75"	0.75"	1.26"											
Crosby Shackle	G2130						G2140						G2160	
Loading Pin Ø	19	19	25	35	51	57	57	70	83	95	121	127	152	180
	3/4 in	3/4 in	1 in	1 3/8 in	2 in	2 1/4 in	2 1/4 in	2 3/4 in	3 1/4 in	3 3/4 in	4 3/4 in	5 in	6 in	7 1/8 in

Wireless Loadshackle



FEATURES AND BENEFITS

- Wireless Range of 1000m or 3280ft
- Electronics housed in hard anodised enclosure
- Environmentally sealed to IP67 or NEMA6
- Battery Life of 1200hrs from 4 x AA batteries
- Internal Antennae
- Remote On-Off from handheld display or software
- Supplied with a load-centring bobbin
- 2-year warranty
- Complies with ASME B30.26
- Design validated by F.E.A.
- ATEX Zones 0, 1 & 2 available
- Bluetooth option is available and is supplied with a free HHP App for iOS and Android
See page 27

Straightpoint's Wireless Loadshackle (WLS) provides the perfect solution to limited headroom or super heavy lift projects. Available from stock in capacities from 3.25t to 400t (up to 3000t available POA), the WLS is constructed using industry-leading shackles from Crosby.

Three versions of the WLS are available:

- Long range 2.4GHz version providing industry-leading wireless range of 1000m or 3280ft to SP's SW-HHP handheld or software options.
- Bluetooth output and can be connected to any smart phone running SP's free HHP app on iOS or Android, at ranges up to 100m or 328ft.
- ATEX/IECEx for hazardous areas, zones 0, 1 & 2. Providing a wireless range of up to 500m or 1640ft to SW-HHP-ATEX handheld.

Each WLS is proof tested, then equipped with a hard-anodised aluminium electronics enclosure. Contained within this enclosure is an internal chassis providing IP67 or NEMA6 environmental protection, even with the battery cover plate missing.

Featuring industry leading wireless technology, the WLS can maintain an update rate of 3Hz. It can be easily configured to run at industry-leading speeds of up to 200Hz, if required for dynamic load measurement projects.

Utilising easily sourced AA alkaline batteries, the WLS features advanced circuitry, designed to protect the unit from damage associated with incorrectly installed batteries. This circuitry extends battery life, and the use of easily-sourced alkaline batteries, eliminating issues associated with rechargeable battery pack charging, failure and replacement.

The WLS may also be used with Straightpoint's SW-PTP software package, allowing the operator to perform load tests at a safe distance and generate real-time test certificates on site.

A full array of wireless accessories are also available including wireless score board, overload alarm and base station with analogue (4-20mA) or 2 relay or RS485 ASCII outputs.

Also available with hazardous area approval. Zones 0, 1 & 2



ATEX / IECEx
Ex ia II CT4 Ga

Certification numbers:
WLS ATEX
IECEX SIR 16.0041X / SIRA 16ATEX2108X / CSAE 22UKEX1266X
SW-HHP ATEX
IECEX SIR 15.0072X / SIRA 15ATEX2196X / CSAE 22UKEX1267X

Add 'ATEX' to the part number when ordering ATEX/IECEX products. For example: WLS3.25T-ATEX

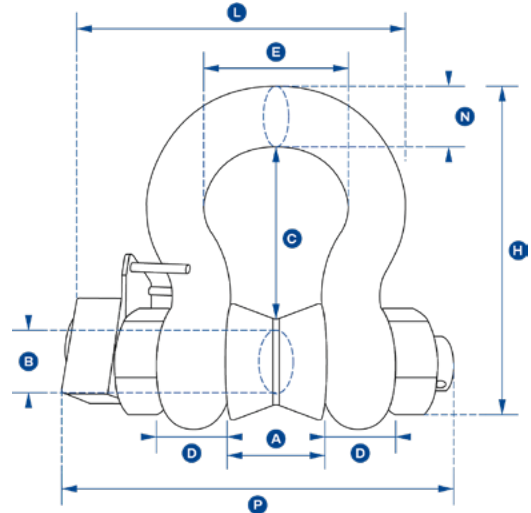

SP Model	WLS3.25T	WLS6.5T	WLS12T	WLS25T	WLS55T	WLS85T	WLS120T	WLS200T	WLS300T	WLS400T
Crosby Part	2789186	2789200	2789183	2789185	2789199	2789201	2789172	2789184	2789188	2789189
Capacity	3.25te	6.5te	12te	25te	55te	85te	120te	200te	300te	400te
	7150lb	14300lb	26400lb	55000lb	120000lb	185000lb	260000lb	440000lb	660000lb	880000lb
Resolution	0.005te	0.005te	0.01te	0.02te	0.05te	0.05te	0.1te	0.2te	0.5te	0.5te
	10lb	10lb	20lb	50lb	100lb	100lb	200lb	200lb	1000lb	1000lb
Units	tonne	tonne	tonne	tonne	tonne	tonne	tonne	tonne	tonne	tonne
	lb	lb	lb	lb	lb	lb	lb	lb	lb	lb
Weight	2.8kg	3.2kg	8kg	18kg	25kg	85kg	125kg	260kg	405kg	662kg
	6.16lb	7lb	17.6lb	40lb	55lb	187lb	276lb	573lb	893lb	1459lb
Safety Factor	5:1 when used with bobbin									
Battery Type	Loadcell 4x AA alkaline									
Battery Life	Loadcell 1200 hrs continuous (500 hrs if Bluetooth)									
Operating Temp	-10 to +50 °C / 14 to 122°F									
Accuracy	+/- 1% FS									
Frequency	2.4GHz									
Range (Max)	1,000 m (100 m if Bluetooth) 3,280 ft (328 ft if Bluetooth)									
Data Rate	3 updates per second									
Protection	IP67 / NEMA6									
Dimension A	26.9	36.6	51.5	73	82.5	127	144	180	205	230
	1.06	1.44	2.03	2.87	3.25	5.00	5.66	7.09	8.07	9.06
Dimension ØB	19.1	25.4	35.1	51	57	83	95	125	150	175
	0.75	1.00	1.38	2.01	2.24	3.26	3.74	4.92	5.91	6.89
Dimension C	56.9	79.7	113	170	189.5	317	364	432.2	505	547.7
	2.24	3.14	4.45	6.69	7.46	12.48	14.33	17.02	19.88	21.56
Dimension D	14.46	20.6	29.5	44.5	51	80	89	110	120	160
	0.57	0.81	1.16	1.75	2.01	3.14	3.50	4.33	4.72	6.30
Dimension E	42.9	58	82.5	127	146	190	238	280	305	325
	1.69	2.28	3.25	5.00	5.75	7.48	9.37	11.02	12.01	12.80
Dimension H	106	148	210	313	348	539	624	769	904	1006.5
	4.17	5.83	8.27	12.32	13.70	21.22	24.56	30.28	35.59	39.63
Dimension L	135	156.5	201	275	306	393	445	529.7	586.7	667.2
	5.31	6.16	7.91	10.83	12.05	15.47	17.51	20.85	23.10	26.27
Dimension N	17.5	24.6	35.1	57	61	85	95	120	140	160
	0.69	0.97	1.38	2.24	2.40	3.34	3.74	4.72	5.51	6.30
Dimension P	150	173	222	290	317	448	488	600	657	765
	5.91	6.81	8.74	11.42	12.48	17.63	19.21	23.62	25.87	30.12
Crosby Shackle	G2130	G2130	G2130	G2130	G2140	S2135				

BlueLink

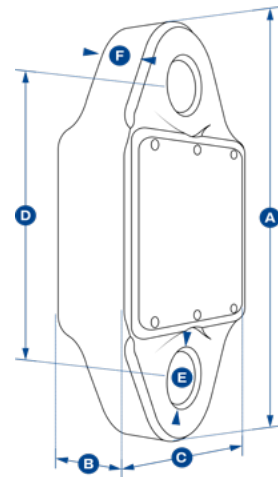
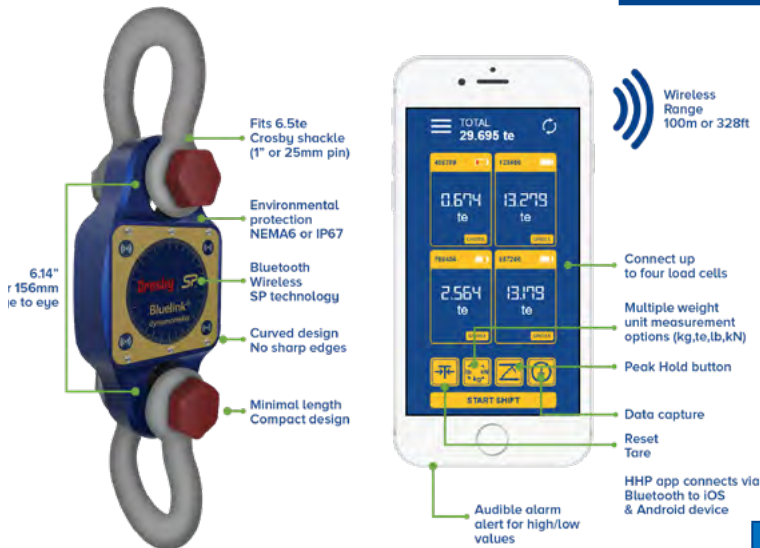

Designed to replace outdated mechanical products still in the field, this 14,300lb (6500kg) Dynamometer, the 'BlueLink', features SP's proprietary Bluetooth wireless technology.

The Bluetooth signal effortlessly connects to any iOS or Android smartphone that has our free HHP app installed, providing the operator with a wireless range of up to 328ft or 100m. This allows them to stand in a safe position from the load, with no requirement to read a load on the load cell itself. The app will also allow the operator to log data versus time, or on events such as over or underload. An adjustable alarm will alert the operator on their smartphone if any overload is occurring.

Constructed from high-quality aerospace grade aluminium, which is then hard-anodised, it features an advanced internal design structure. This design provides the product with an unrivalled strength to weight ratio. The use of a separate internal sealed enclosure administers the load cell's electronic components with IP67 or NEMA6 environmental protection, even with the battery cover plate missing. All these features makes it an industry-leading compact dynamometer, even more suitable for use in the harshest industrial or leisure environments.

The BlueLink is powered by four standard AA alkaline batteries that provide in excess of 500 hours transmission time. Its internal antennae ensures safe transmissions of loads to an accuracy of $\pm 0.2\%$ FS.

SP Model	BLD6T5
Crosby Part	2789218
Capacity	6.5 te
	14,300 lb
Resolution	0.001 te
	2 lb
Weight	1.5 kg
	3.3 lb
Safety Factor	6:1
Battery Type	4 x AA alkaline
Battery Life	500 hrs
Operating Temp	-10 to +50° C / 14 to 122° F
Accuracy	+/- 0.2% of full scale
Range (Max)	100 m / 328 ft
Data Rate	3Hz
Protection	IP67 / NEMA6
Dimension A	224
	8.82
Dimension B	44
	1.73
Dimension C	113
	4.45
Dimension D	156
	6.14
Dimension ØE	27.5
	1.08
Dimension F	33
	1.3
Crosby Shackle	G2130
Loading Pin Ø	25
	1 in

6.5t Self indicating dynamometer (SID)

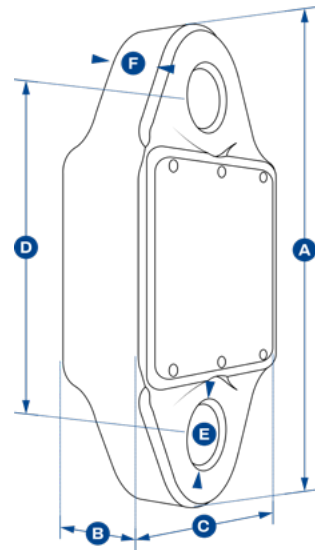

This self-indicating version of the product ‘Bluelink’ has advanced features and benefits, providing solutions where close-up load monitoring is required, such as when operating lever or chain hoists at height or lifting vehicle motors.

The advanced microprocessor-based electronics provide the SID with high-speed read rates, extreme resistance to industrial-level noise and unprecedented stability. It features full-function push button controls for:

- Tare and preset tare
- Selectable measurement units (lbs, kg, kN and tonnes)
- 100Hz high-speed peak hold
- Audible set-point alarm
- Overload counter

Providing accurate load measurement and incident and injury prevention this dynamometer is rigged using industry-standard shackles such as Crosby G2130, the compact design minimises headroom loss (6.14" or 156mm from eye to eye).

Constructed with high-grade aircraft quality aluminium and with a safety factor of over 500%, its lightweight design does not sacrifice on strength in fact Crosby SP's link style dynamometers are on average 30% lighter than their closest competitor with the same safety rating.

SP Model	SID6T5
Crosby Part	2789709
Capacity	6.5 te
	14,300 lb
Resoulution	0.001 te
	2 lb
Weight	1.5 kg
	3.3 lb
Safety Factor	6:1
Battery Type	9v PP3
Battery Life	80 hrs continuous
Operating Temp	-10 to +50° C / 14 to 122° F
Accuracy	+/- 0.2% of full scale
Display Type	6 digit 25 mm LCD / 6 digit 1 in LCD
Protection	IP65 / NEMA 4X
Dimension A	224
	8.82
Dimension B	44
	1.73
Dimension C	113
	4.45
Dimension D	156
	6.14
Dimension ØE	27.5
	1.08
Dimension F	33
	1.3
Crosby Shackle	G2130
Loading Pin Ø	25
	1 in

LoadSafe

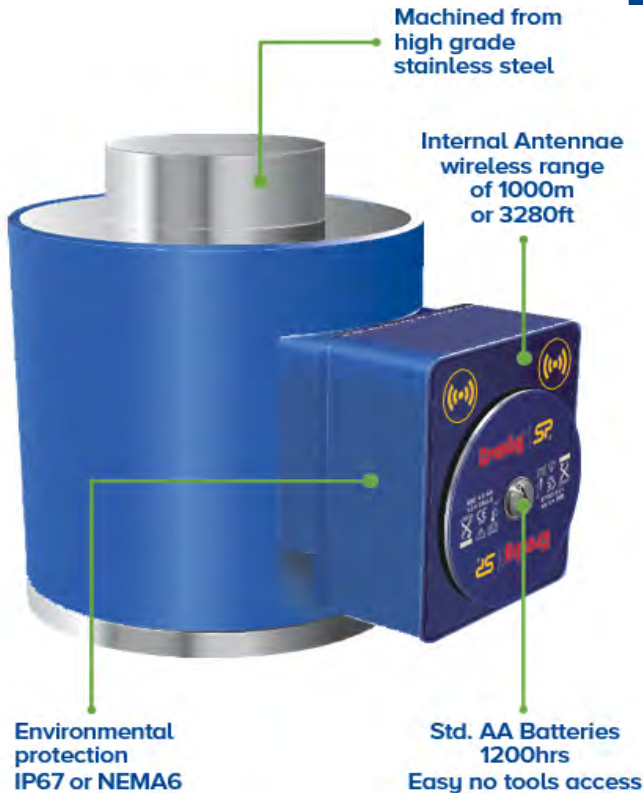

FEATURES AND BENEFITS

- Proprietary 2.4 GHz wireless
 - Accuracy of $\pm 0.1\%$ FS
 - Environmentally sealed to IP67 or NEMA6
 - Stocked capacities up to 1000t
 - Industry leading wireless range up to 1000m or 3280ft
 - Internal antennae
 - ATEX & IECEx version for hazardous area zones 0, 1 & 2 available
 - Battery life of 1200hrs
 - Compact size
 - Remote On-Off from handheld display or software
 - Design validated by F.E.A.
- Bluetooth option is available and is supplied with a free HHP App for iOS and Android See page 27

The Straightpoint LoadSafe Compression Load Cell.

No longer hindered by troublesome and hard to maintain cables, large-scale projects can now be completed in a fraction of the time previously required.

Multiple compression load cells can all connect wirelessly to INSIGHT via a USB dongle, their iOS or Android app (If Bluetooth), or their SW-HHP wireless handheld display.

Maintenance and repair costs are all but eliminated due to the absence of cables and connectors.

The flexibility of the product opens the door to a large number of applications in the heavy lift, energy, defence, rigging, shipping, and general transportation sectors.

Crosby | Straightpoint's LoadSafe is machined from high grade 17-4PH stainless steel, providing excellent strength and corrosion resistance, which makes them suitable for the most arduous industrial conditions.

Three versions of the WNI are available:

- Long range 2.4GHz version providing industry-leading wireless range of 1000m or 3280ft to SP's SW-HHP handheld or software options.

- Bluetooth output and can be connected to any smart phone running SP's free HHP app on iOS or Android, at ranges up to 100m or 328ft.

- ATEX/IECEx for hazardous areas, zones 0, 1 & 2. Providing a wireless range of up to 500m or 1640ft to SW-HHP-ATEX handheld.

Connected to Crosby | Straightpoint's INSIGHT, the WNI load cell can be used to weigh and verify centre of gravity of large and heavy objects, which may not be evenly proportioned. The system will report weight on each individual load cell, total weight and C-of-G in an html report based on ISO19901.

Also available with hazardous area approval. Zones 0, 1 & 2



ATEX / IECEx Ex ia II CT4 Ga

Certification numbers:
WNI ATEX

IECEX SIR 16.0041X / SIRA 16ATEX2108X / CSAE 22UKEX1266X
SW-HHP ATEX

IECEX SIR 15.0072X / SIRA 15ATEX2196X / CSAE 22UKEX1267X

**Add 'ATEX' to the part number
when ordering ATEX/IECEX products.
For example: WNI5TC-ATEX**

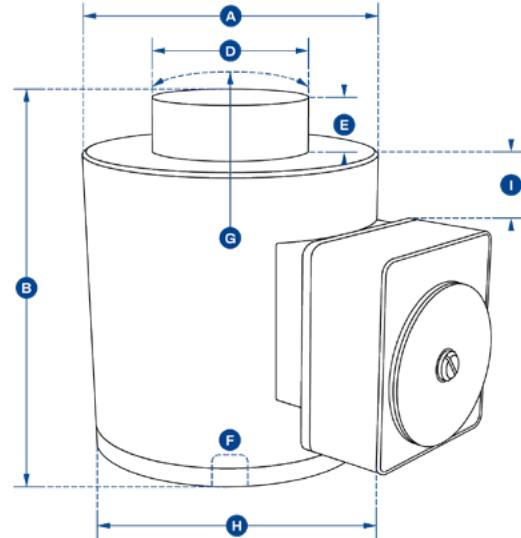

SP Model	WNI5TC	WNI10TC	WNI25TC	WNI50TC	WNI100TC	WNI150TC	WNI300TC	WNI500TC	WNI1000TC
Crosby Part	2789197	2789191	2789193	2789196	2789190	2789192	2789194	2789195	2789138
Capacity	5te	10te	25te	50te	100te	150te	300te	500te	1000te
	11,000lb	22,000lb	55,000lb	110,000lb	220,000lb	330,000lb	660,000lb	110,0000lb	2200000lb
Resolution	0.001te	0.002te	0.005te	0.01te	0.05te	0.05te	0.1te	0.2te	0.5te
	2lb	5lb	10lb	20lb	100lb	100lb	200lb	500lb	1000lb
Units	tonne	tonne	tonne	tonne	tonne	tonne	tonne	tonne	tonne
	lb	lb	lb	lb	lb	lb	lb	lb	lb
Weight	6.2kg	6.2kg	6.2kg	6.2kg	15.5kg	15.5kg	65kg	65kg	172kg
	13.64lb	13.64lb	13.64lb	13.64lb	34lb	34lb	143lb	143lb	379lb
Safety Factor	3:1								
Battery Type	Loadcell 4 x AA alkaline								
Battery Life	Loadcell 1200 hrs continuous (500 hrs if Bluetooth)								
Operating Temp	-10 to +50 °C / 14 to 122°F								
Accuracy	+/- 0.1% FS								
Frequency	2.4GHz								
Range (Max)	1000 metres (100m if Bluetooth) / 3280 ft (328 ft if Bluetooth)								
Data Rate	3Hz (configurable to 200 Hz)								
Protection	IP67 / NEMA6								
Dimension ØA	100	100	100	100	152	152	185	185	362
	3.94	3.94	3.94	3.94	5.98	5.98	7.28	7.28	14.25
Dimension B	127	127	127	127	184	184	300	300	310
	5.00	5.00	5.00	5.00	7.24	7.24	11.81	11.81	12.20
Dimension ØD	59	59	59	59	80	80	155	155	270
	2.32	2.32	2.32	2.32	3.15	3.15	6.10	6.10	10.63
Dimension E	16	16	16	16	26	26	27.5	27.5	40
	0.63	0.63	0.63	0.63	1.02	1.02	1.08	1.08	1.57
Dimension F	M18 x 2.5	M18 x 2.5	M18 x 2.5	M20 x 2.5	M20 x 2.5	M20 x 2.5	M20 x 2.5	M20 x 2.5	M30x3.5
	M18 x 2.5	M18 x 2.5	M18 x 2.5	M20 x 2.5	M20 x 2.5	M20 x 2.5	M20 x 2.5	M20 x 2.5	M30x3.5
Dimension G	152	152	152	152	432	432	432	432	950
	5.98	5.98	5.98	5.98	17.01	17.01	17.01	17.01	37.40
Dimension H	158	158	158	158	208	208	241	241	422
	6.22	6.22	6.22	6.22	8.19	8.19	9.49	9.49	16.61
Dimension I	6	6	6	6	7	7	21.5	21.5	102
	0.23	0.23	0.23	0.23	0.27	0.27	0.27	0.54	4.02



Clamp on Line Tensiometer

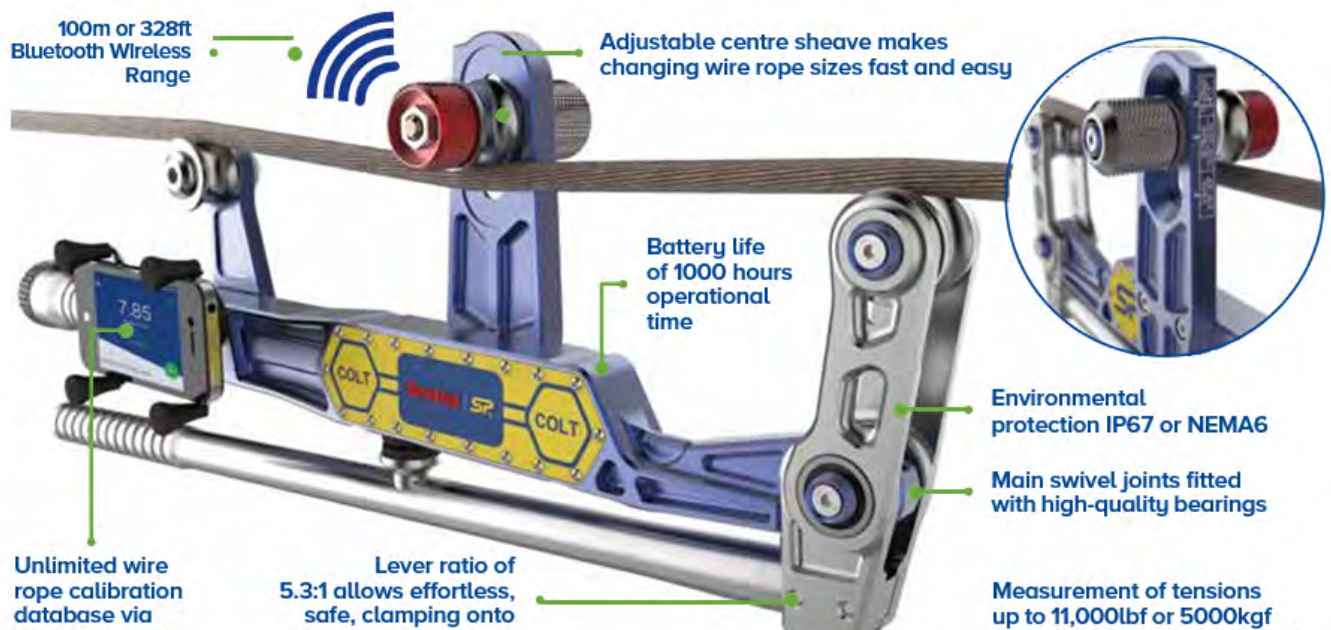

The Straightpoint COLT is a lightweight wire rope tension meter, for fast and accurate measurement of tensions up to 11,000lb or 5000 kg and up to 1" or 25mm diameter.

Manufactured using an integral, high accuracy, Bluetooth module, the COLT transmits load data wirelessly to any smart device running our free Android or iOS app.

Constructed from aerospace grade aluminium, the COLT digital tensiometer is lightweight and easy to handle. Its main operational application is to be attached to wires/cables that are already under tension. Once in place, it allows the operator to quickly check tension on cables or wire ropes set at any angle.

A built-in magnetic smart device holder allows the COLT to be used as a traditional tension meter with on board display, or the smartphone can be handheld or mounted elsewhere.

Supplied in a purpose made carry case, the COLT is portable and utilises standard alkaline batteries, making it perfect to carry out on-site cable tension testing anywhere in the world.

An included calibration verification tool (CVT) allows the operator to self-check and verify calibration accuracy, in the field, if required.

FEATURES & BENEFITS

- Unlimited wire rope calibration database
- Main swivel joints fitted with high-quality bearings
- Lever ratio of 5.3:1 allows effortless, safe, clamping onto pre-tensioned wire ropes
- Wireless Bluetooth 4.2 range up to 100 metres or 328 feet
- Quick intuitive adjustable centre sheave makes changing wire rope sizes fast and easy
- No easily broken external antennae
- IP67 or NEMA6 for all weather use
- Massive battery life of 1000 hrs operational time

Wirerope Mode:

- Records GPS coordinates
- Logs the local temperature and windspeed from local NOAA
- Ability to also allow elevation of wire rope to be inputted into log
- Camera - take a snapshot of your job to attach to the report

Elevator Mode:

- Car weighing – measure tension on each cable
- Car balancing – calculates balance of 4 cables for adjustment of tension

Applications:

- Guy wire maintenance on cell towers, bridges, flare stacks, antennas and masts
- Guy wire Tower Plumb and Tension
- EHS guy wire, Turnbuckle tensioner
- Wire rope installations, comparing, equalising and measuring
- Architectural wire rope installations
- Median cable barrier tensioning
- Utility cable overhead line monitoring
- Elevator hoist, governor and compensating wire rope maintenance
- Zip lines and assault course testing
- Fall arrest systems
- Metro, tram and rail transit electric wires, and catenary testing
- Ski lifts
- Wire rope tie downs on vessels (using Tirfor)
- Testing tension of ship mast wire ropes.
- Tensioned trellis systems
- Measuring Line Sag
- Elevator installation and maintenance

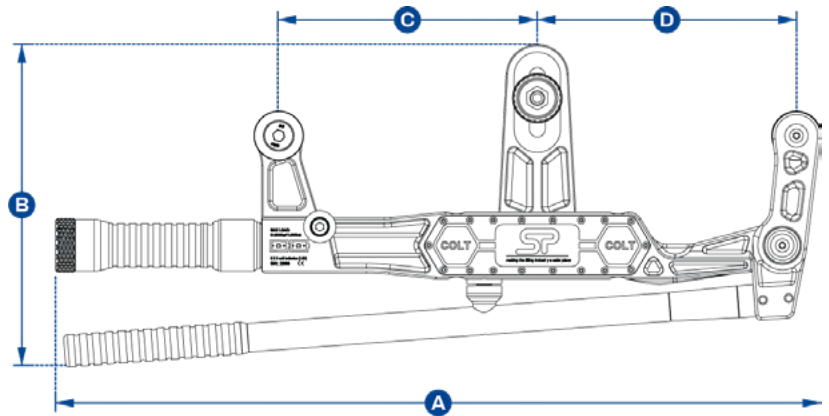

SP Model	COLT5T
Crosby Part	2789000
Max load	5,000 kgf
	11,000 lbf
Resolution	10 kg
	20 lb
Units	kg, lb, tonne, and kN
Min wire rope \varnothing	5 mm
	3/16"
Max wire rope \varnothing	25 mm
	1"
Max line reduction	5 mm with \varnothing 10 mm wire rope
	7/32" with \varnothing 3/8 in wire rope
Wire rope database	Infinite via Android or iOS app
Weight	3.5kg
	7.7lb
Battery Type	2 x 'C' cell batteries
Battery life	1000 hours Bluetooth transmission time
Operating temperature	-25 to +70°C / -13F to 158°F
Protection	IP67/NEMA6
Accuracy	+/- 3% of wire rope max range if \varnothing & construction known
Communication	Bluetooth 4.2
Supported OS version	Android 4.4 onwards & iOS 8 onwards
Dimension A	589 mm
	23.2"
Dimension B	254 mm
	10"
Dimension C	200 mm
	7.9"
Dimension D	200 mm
	7.9"

Specifications assume COLT used on a wire rope with a fixed and flexible end

CVT (Calibration Verification Tool)

**Included:**

CVT (Calibration Verification Tool). In order to ensure that the measurements of the COLT are as accurate as possible, Crosby SP supply a calibration verification rod, specifically designed for this purpose. All supplied in a robust carry case.

Free to download App

iOS



ANDROID



Wire rope tension meter (BOLT)

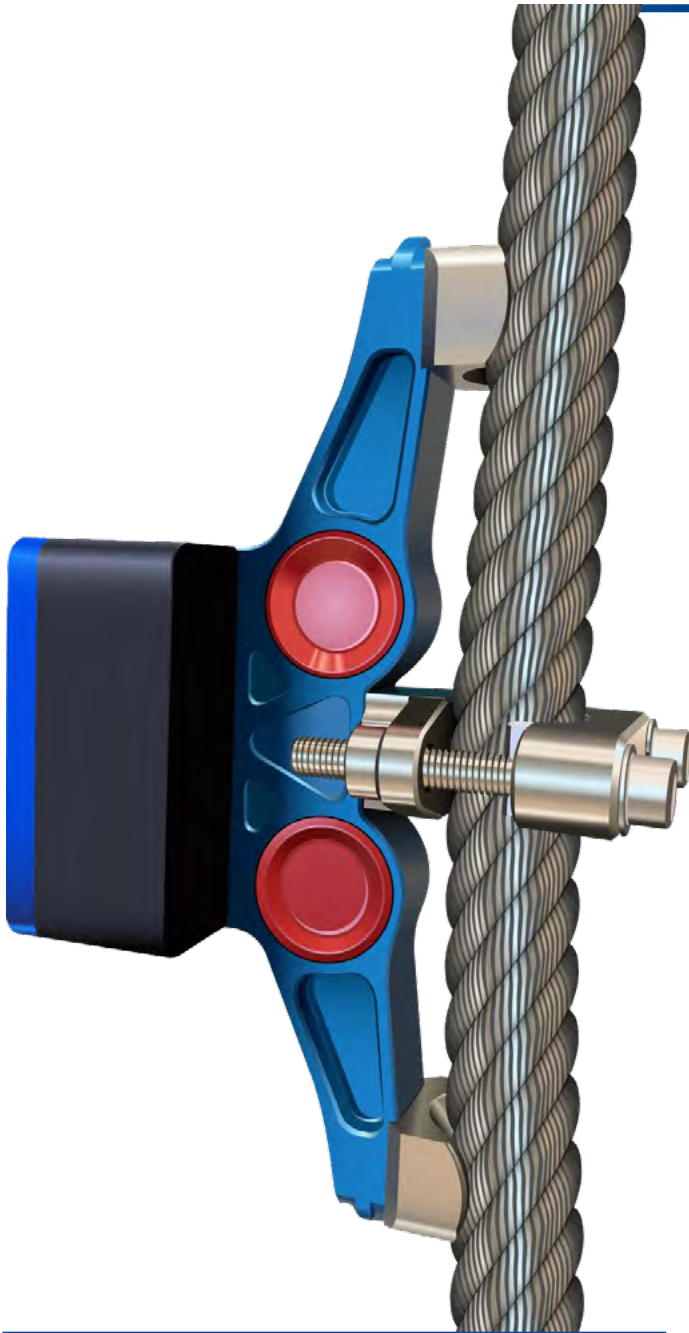

The Crosby Straightpoint Bolt-On-Line-Tensiometer or BOLT is a lightweight wire rope tension meter or shunt tension meter for fast and accurate measurement of tensions up to 20,000lbf / 10,000kgf and up to 1.25" / 32mm diameter wire ropes.

The BOLT is designed to be mounted permanently or temporarily on wire rope or cable installations to monitor the tension and transmit the load via 2.4GHz signal to three options of the receiver:

- **LoadConnect** - A base station allows connection to up to 16 BOLT load cells and transmits data via SMS messaging from any global location with 3G or 4G
- **SW-HHP** - Handheld display with a wireless range of 1000m or 3280ft to up to four BOLTs
- **INSIGHT** - Software multi-channel display and datalogging, connect 126 BOLTs within a wireless range of 700m or 2300ft

Sealed to IP67 or NEMA6 and constructed from aerospace-grade aluminium, the BOLT digital tensiometer is lightweight, easy to handle and operates on wires which are already under tension. Once installed it enables the operator to quickly check tension on cables or wire ropes set at any angle.

BOLT may be powered by the on-board AA batteries for up to 50 days of continuous measures at 3Hz or if needed to be fitted for longer periods or in remote sites may be powered via the LoadConnect base station via low voltage cables or solar battery pack solutions allowing for permanent power.

It is supplied inclusive of an SW-D dongle, to make on-the-spot calibrations to achieve greater accuracy of 2-3%; standard factory accuracy is 3-5%.

FEATURES & BENEFITS

- Proprietary and secure 2.4 GHz Wireless
- Leading Wireless Range of 1000m/3280ft when connected to SW-HHP
- Multiple drop tested from 3 metres or 10 feet.
- Internal Antennae
- Remote On-Off from handheld display or software
- Weatherproof proof allowing mounting in a permanent position on a wire rope or cable

SUPPLIED WITH THE FOLLOWING

- Calibration certificate
- Multi-lingual user manual
- USB Dongle and calibration software
- Carry case

WARRANTY & ASSURANCE

- 2-year warranty
- Design validated by F.E.A.

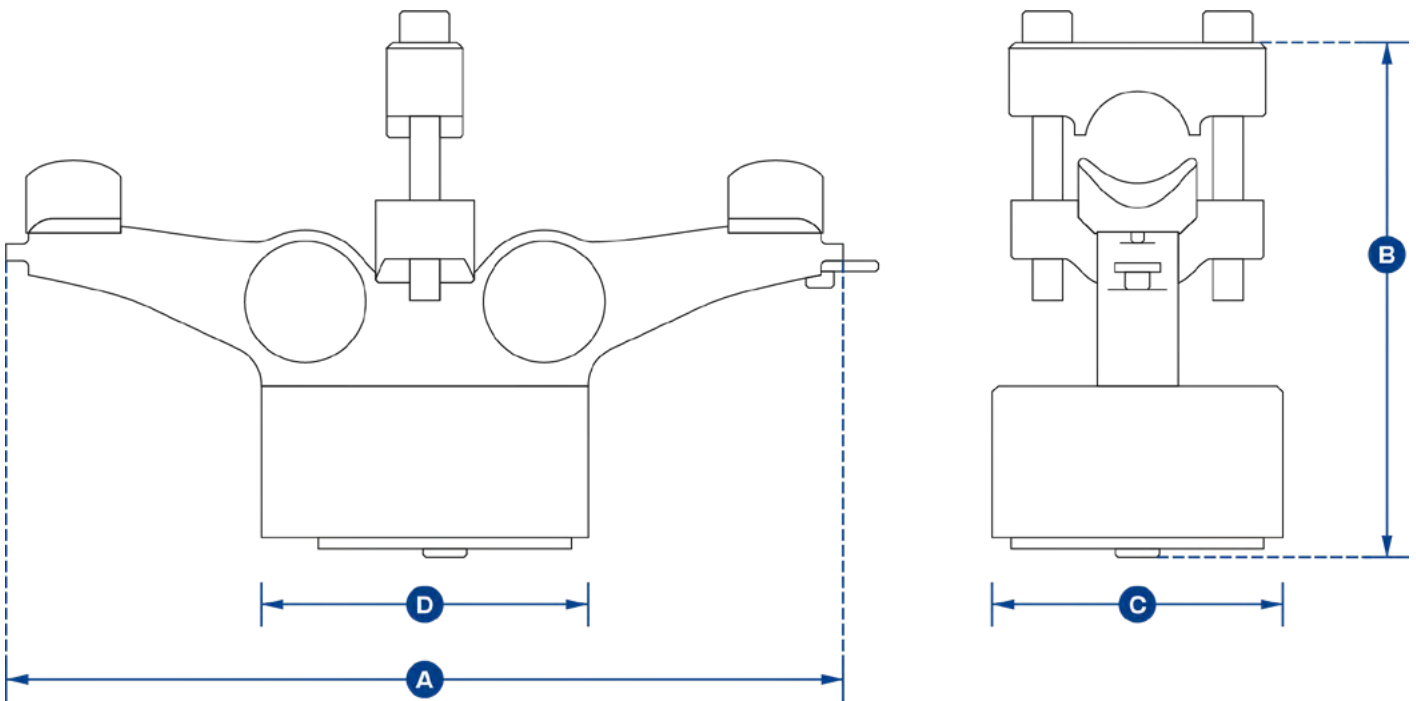

APPLICATIONS

- Guy wire maintenance and monitoring on cell towers, bridges, flare stacks, antennas and masts.
- Guy wire Tower Plumb and Tension
- EHS guy wire, Turnbuckle tensioner.
- Architectural wire rope installations
- Median cable barrier tensioning
- Utility cable overhead line monitoring
- Governor & compensating wire rope maintenance
- Zip lines & assault course testing
- Metro, tram and rail transit electric wires & catenary testing
- Ski lifts
- Tensioned trellis systems

SP Model	BOLT10T
Crosby Part	2789573
Max load	10,000 kgf
	22,000 lbf
Resolution	0.01te
	20 lb
Units	kg, lb, tonne, kN
Min wire rope diameter	16 mm
	5/8 in
Max wire rope diameter	32 mm
	1.25"
Weight	2.1 kg
	4.6 lb
On Board Battery Type	4 x AA cell batteries
Battery life if not externally powered	50 days
Operating temp	-10 to +50 °C / 14 to 122°F
Protection	IP67 / NEMA6
Accuracy	Typically 3-5% of FS
Communication	2.4GHz
Dimension A	259
	10.20
Dimension B	159.1
	6.26
Dimension C	89
	3.50

CableSafe



In addition to the TIMH range, the CableSafe is the continued evolution of Crosby Straightpoint's running line tensiometers. When used in the field, it will allow the user to monitor tension with exceedingly high levels of accuracy, which ensures rope/cables do not become overstretched or break.

When using a capstan winch to unwind electrical cable from a reel/spool, you will be able to integrate the CableSafe within this set-up to ensure that it is being pulled at a safe tension level. This helps the line maintain its transmissions capability, prevent it becoming a fire hazard risk, and it also stops the need of furthering work in order to remove and replace it. The contractor is gifted with decreased liability, dramatically increasing peace of mind. Using CableSafe on cable pulls reduces liabilities on cable installations, making it ideal for the following applications:

- Measure tension when pulling electrical cables – protect against fractures or elongation
- Measuring tension on synthetic rope when erecting delicate structures using gin poles and capstan winch

Another example of best use is during the installation of cell phone towers or similar delicate structures. The product helps ensure structure-to-ground ropes which are connected to a gin pole and pulley system. Do not exceed maximum tension whilst lifting sections of the tower to the top because there can be the possibility of the rope becoming snagged, causing greater tension to be loaded upon the system. With heavy materials being lifted to great heights; this would create a major safety hazard leading to a catastrophic failure, endangering lives. Avoid the unknown through accurate monitoring, especially when risks are high.

What distinguishes it, apart from previous versions of this type, is the developed lightweight design, allowing easy transportation and usage. Providing up to 500 hours battery life, you can be assured there will not be any loss of power before your work day has ended. High level IP67 or NEMA6 ingress protection allows it to be used in a variety of heavy weather conditions and dusty environments. These features, as a collective, means that it will be an invaluable and reliable tool in your work-related armoury.

The five-wheel design and gravity catches, with top sheave pins, allows for fast and simple rope attachment set-up. The accuracy is further improved over three-wheel alternatives.

When used with a cable/rope pulling device, you can remotely monitor the tension on the line using your smart handheld device via a Bluetooth connection*. With the operator locating themselves up to 100m or 328ft away from the CableSafe, it will allow them to survey job progress at a safe distance.

*The 'HHP' app is available to download for free (Android/iOS) and is compatible with all SP Bluetooth Products.

- Fibre-optic cable pulling using turret winches
- Water gates for dams
- Offshore rescue and retrieval
- Capstan rope/cable winding
- Broadcast and telecommunications
- Erecting towers (maintaining structural capacity)
- Service and maintenance of cell towers

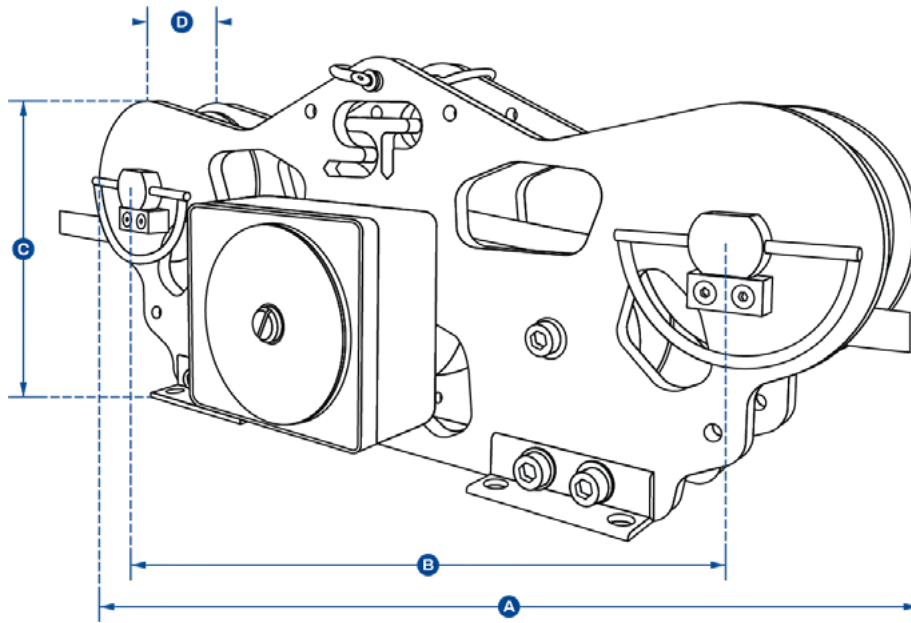

SP Model	Cablesafe	Cablesafe-WD
Crosby Part	2789219	2789399
Capacity	10 te	10 te
	22,000 lb	22,000 lb
Resolution	0.01 te	0.01 te
	20 lb	20 lb
Wire rope Ø	4-19 mm	9.5-30 mm
	5/32" - 3/4"	3/8" - 1-3/16"
Weight	4.5 kg	8 kg
	10 lb	17.6 lb
Battery Type	Wireless version 4x AA alkaline	
Battery Life	500 hrs	
Operating Temp	-10 to +50 °C / 14 to 122°F	
Accuracy	2% FS	
Range (Max)	Bluetooth 100m / 328ft	
Protection	IP67 / NEMA6	
Max Speed	600 m per minute	600 m per minute
	1968 ft per minute	1968 ft per minute
Dimension A	422 mm	422 mm
	16.62"	16.62"
Dimension B	328 mm	328mm
	12.9"	12.9"
Dimension C	152 mm	152 mm
	5.98"	5.98"
Dimension D	36.5 mm	50.5 mm
	1.43"	2"

FEATURES AND BENEFITS

- Simple to use and set up
- Remote monitoring using smart phone via Blue tooth, see page 27
- Rapid tension force measurement - Up to 600m or 1968ft per minute
- Able to be used in all weather and air quality conditions
- Easy to install and replace batteries (4 x AA standard Alkaline)
- Fully constructed from aerospace-grade aluminium with anodised finish
- Five wheel design improving accuracy
- Linchpins are fitted to the top sheave pins making wire rope installation quick and simple
- Maintenance free heavy duty bearings
- Compatible with a wide range of synthetic rope/electrical cable diameters – 4-30mm or 5/32" - 1 3/16"
- Design validated by F.E.A.
- IP67 ingress protection or NEMA6 – heavy protection against dust and rain

Running Line Dynamometer

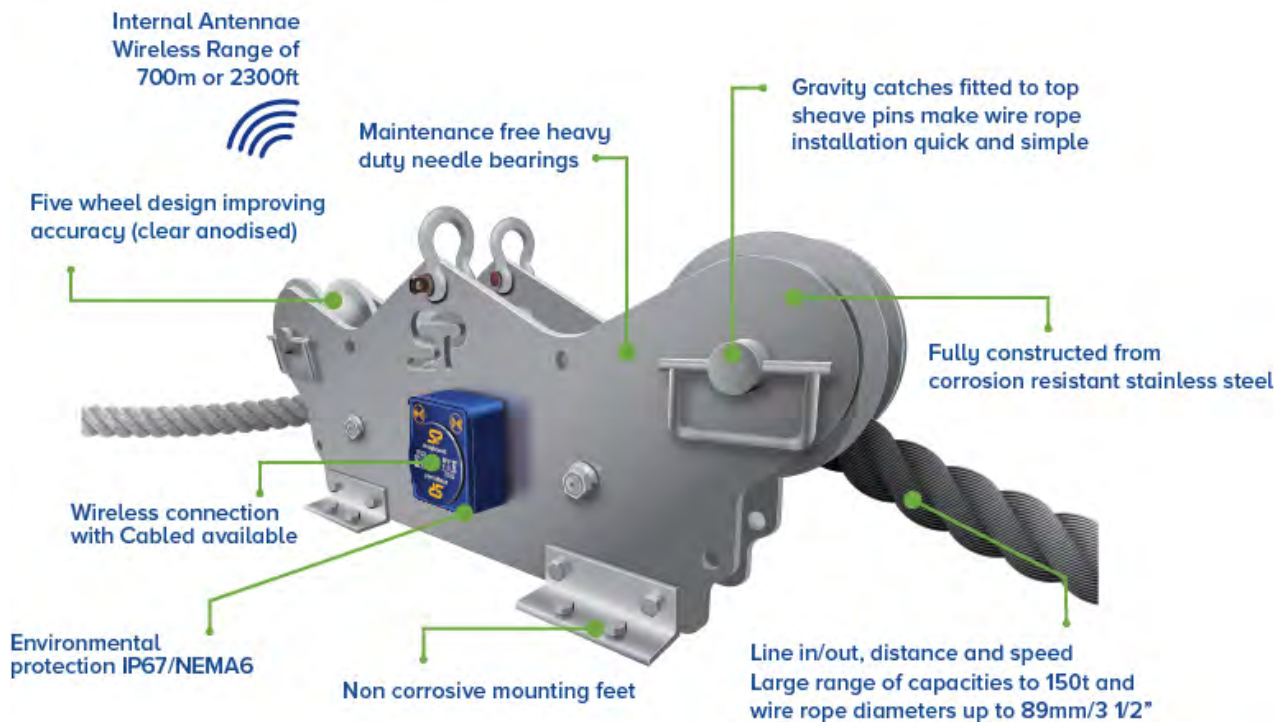

The TIMH range is a Wireless Running Line Tensiometer or RLTM built with dockside, marine, offshore, towage and salvage applications in mind. It is particularly useful when there is no anchor or dead end on the line to rig an SP Radiolink or Loadlink digital dynamometer. It measures tension force at speeds up to 20m/min or 65ft/min.

Two versions of the TIMH are available:

- Long range 2.4GHz version providing industry leading wireless range of 700m or 2300ft to SP's SW-HHP handheld or software options.
- Bluetooth output and can be connected to any smart phone running SP's free HHP app on iOS or Android at ranges up to 100m or 328ft.

The TIMH is constructed from marine grade stainless steel and is suitable for many wire rope configurations up to 150t and will, as an option, calculate lineout and speed. The TIMH has several mounting points featured in its unique design but if other mounting options are required, Straightpoint can provide a custom engineered solution specific to your application.

Available as a wireless or cabled system, utilising Straightpoint's HHP range of handheld displays or SW-MWLC software, this impressive Running Line Dynamometer or RLTM is available to ship from stock, to anywhere in the world, within days.

FEATURES AND BENEFITS

- Measure tension, line speed and distance
- Five-wheel design improving accuracy
- Cabled or wireless options
- Fully constructed from corrosion-resistant stainless steel
- IP67 or NEMA6 Loadpin
- Industry leading battery life of 1200hrs (wireless)
- Maintenance free heavy duty bushes
- Large range of capacities to 150t and wire rope diameters up to 89mm or 3½"
- Options for lineout and speed available
- Software available to data log and monitor or analogue outputs
- Design validated by F.E.A.
- Bluetooth option is available and is supplied with a free HHP App for iOS and Android
See page 27

Also available with hazardous area approval. Zones 0, 1 & 2



ATEX / IECEX Ex ia II CT4 Ga

Certification numbers:

TIMH ATEX

IECEX SIR 16.0041X / SIRA 16ATEX2108X / CSAE 22UKEX1266X

SW-HHP ATEX

IECEX SIR 15.0072X / SIRA 15ATEX2196X / CSAE 22UKEX1267X

**Add 'ATEX' to the part number
when ordering ATEX/IECEX products.
For example: TIMH10T-ATEX**

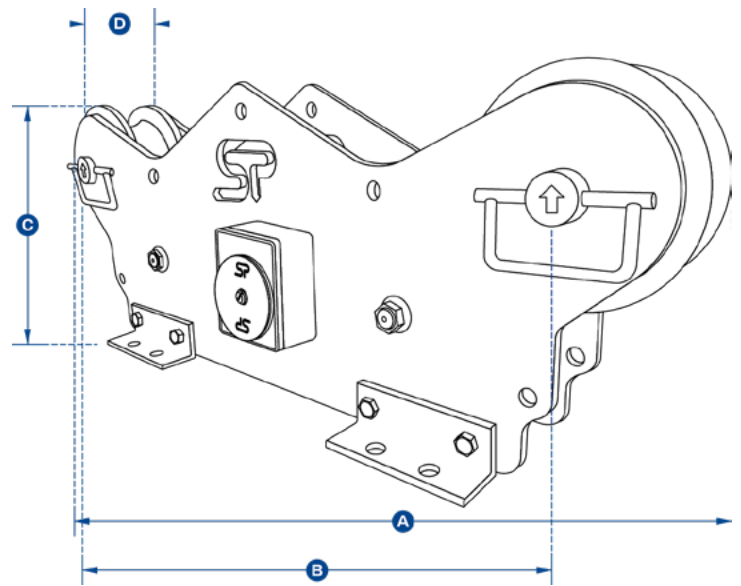

SP Model	MTIMH10TRD	TIMH10TRD	TIMH25TRD	TIMH56TRD	TIMH80TRD	TIMH150TRD
Crosby Part number	2789054	2789136	2789139	2789144	2789146	2789270
Capacity	10 te	10 te	25 te	56 te	80 te	150 te
	22,000 lb	22,000 lb	55,000 lb	123,200 lb	176,000 lb	330,000 lb
Resolution	0.01 te	0.01 te	0.02 te	0.05 te	0.1 te	0.2 te
	20 lb	20 lb	50 lb	100 lb	200 lb	500 lb
Wire rope Ø mm	4-19 mm	13-19 mm	16-26 mm	28-38 mm	40-52 mm	52-89 mm
	5/32 in - 3/4 in	1/2' in - 3/4' in	5/8 in - 1 in	1 1/8 in - 1 1/2 in	1 5/8 in - 2 in	2 in - 3 1/2 in
Weight	9 kg	90 kg	86 kg	81 kg	76 kg	230 kg
	20 lb	198 lb	190 lb	179 lb	168 lb	506 lb
Battery Type	Wireless version 4x AA alkaline					
Battery Life	Wireless version 1200 hrs					
Operating Temp	-10 to +50 °C / 14 to 122°F					
Accuracy	2% FS					
Range (Max)	700 m / 2300 ft					
Protection	IP67 / NEMA 6					
Max Speed	50 m per minute / 164 ft per minute	20 m per minute / 65 ft per minute				
Line out and speed	Yes via SW-MWLC software					
Dimension A	422 mm	865 mm				1250 mm
	16.62 in	34.05 in				49.2 in
Dimension B	328 mm	674 mm	674 mm	674 mm	674 mm	1050 mm
	12.9 in	26.53 in	26.53 in	26.53 in	26.53 in	41.33 in
Dimension C	152mm	329mm	329mm	329mm	329mm	416mm
	5.98 in	12.95 in	12.95 in	12.95 in	12.95 in	16.37 in
Dimension D	36 mm	111 mm	111 mm	111 mm	111 mm	153 mm
	1.4 in	4.37 in	4.37 in	4.37 in	4.37 in	6.02 in

TowCell

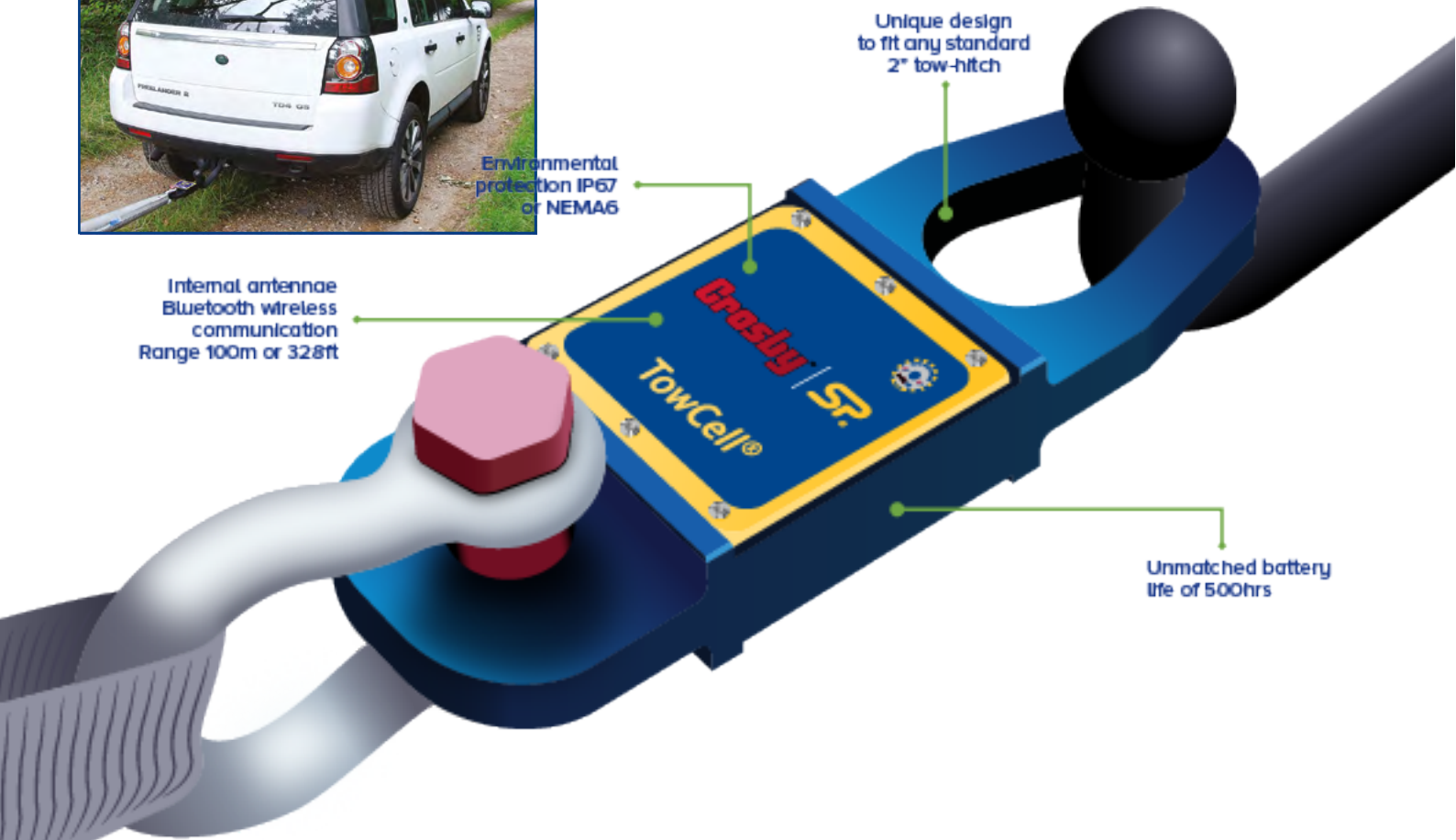

Straightpoint has developed a 25kN, wireless load cell specifically engineered for the emergency services, salvage and 4 x 4 industries. The Towcell® allows for increased safety and the avoidance of costly overloads by providing real-time monitoring of tensile towing forces during recovery, clearance and salvage efforts. The Towcell® is rugged, lightweight, compact and can be installed, with ease, onto any tow bar, whether it's a standard 52mm or 2" ball or pin assembly and is ready to use in seconds.

Modelled after Straightpoint's best-selling Radiolink plus, the Towcell® is constructed of high-quality aircraft grade aluminium. It features an advanced internal design structure, providing the product with an unrivalled strength to weight ratio. This optimal balance allows for the use of a separate internally sealed enclosure. This administers the internal electronic components with an IP67 or NEMA6 waterproof environmental protection, even with the battery cover plate missing.

FEATURES AND BENEFITS

- Unique design to fit any standard 2" tow-hitch
- Unmatched battery life of 500hrs
- Waterproof IP67 or NEMA6
- Internal antennae
- Compact size and lightweight
- Proprietary 2.4 GHz wireless communication
- Design validated by F.E.A.

- Bluetooth enabled and is supplied with a free HHP App for iOS and Android
See page 27

Easily sourced AA alkaline batteries offer massive battery life of 500 hours, and the Towcell® utilises an unbreakable internal antennae.



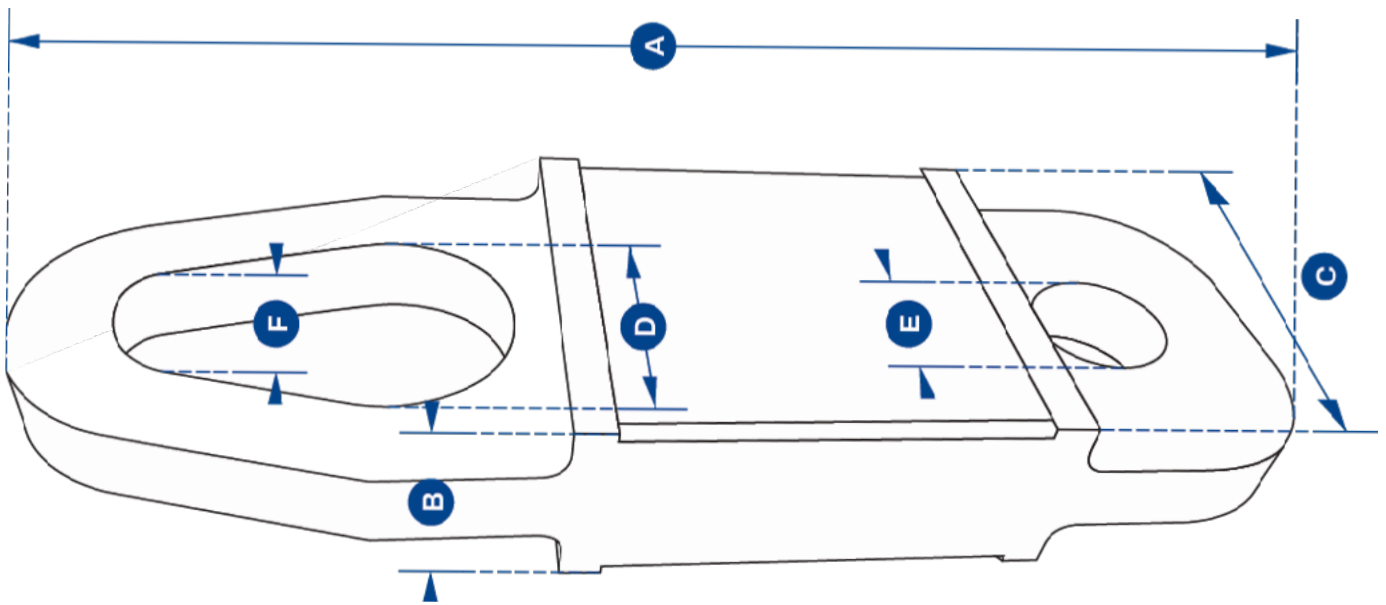

SP Model	Towcell
Crosby Part	2789271
Capacity	25 kN
Resolution	0.01 kN
Weight	1.4 kg 3 lb
Safety Factor	5:1
Battery Type	4 x AA alkaline
Battery Life	500 hrs continuous
Operating Temp	-10°C to +50°C / 14°F to 122°F
Accuracy	+/- 0.1% FS
Range (Max)	100 m / 328 ft
Data Rate	50 Hz
Protection	IP67 / NEMA6
Dimension A	300 mm 11.81 in
Dimension B	43 mm 1.70 in
Dimension C	104 mm 4.09 in
Dimension ØD	51 mm 2.00 in
Dimension ØE	27mm 1.06 in
Dimension ØF	31 mm 1.22 in

ChainSafe

ChainSafe is a Bluetooth wireless tension load cell capable of load monitoring of capacities up to 4te. Specifically designed for use along the length of the chain with an array of The Crosby Group chain fittings for applications where chain lashing and tie downs are used in industries such as transportation.

The ChainSafe design has an unrivalled strength to weight ratio with a completely sealed stainless steel enclosure providing IP67 or NEMA6 environmental protection, making this industry-leading dynamometer even more suitable for use in the harshest environments.

The versatile chain load monitoring device has an update rate of 1Hz and the Bluetooth signal effortlessly connects to any iOS or Android smartphone that has our free HHP app installed. This will provide the operator with a wireless range of up to 328ft or 100m – measuring the load from a safe distance. The app will also allow the operator to log data versus time or on events such as over or underload, and the adjustable alarm will alert the operator on their smartphone if any overload is occurring.



FEATURES AND BENEFITS

- Designed to work along the length of 10mm chain
- Bluetooth wireless range of 100m/328ft
- Lightweight load cell easily attached to the length of chain
- No battery change required - Battery life 5 years based on 3hrs use per day
- Environmentally protected to IP67/NEMA6
- Internal Antennae.
- Bluetooth enabled and is supplied with a free HHP App for iOS and Android
See page 27

N.B. Fittings not included

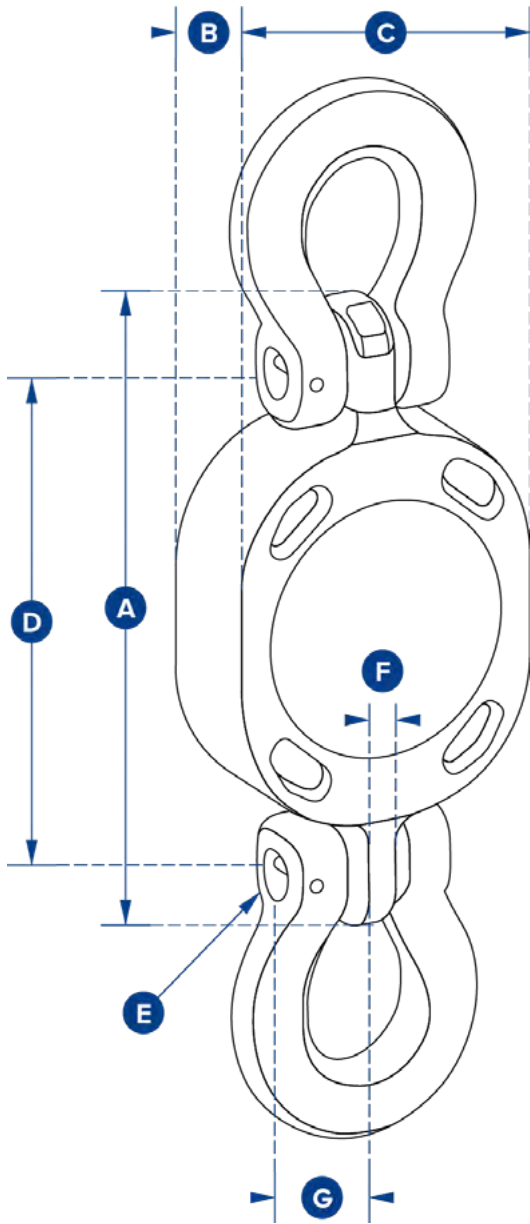

SP Model	CS4T
Crosby Part	2789536
Capacity	4 te
	8800 lb
Resolution	0.002 te
	4 lb
Weight	2.5 kg
	5.5 lb
Safety Factor	4:1
Battery Type	Lithium Thionyl Chloride (non replaceable)
Battery Life	5 years based on 3 hrs use per day.
Operating Temp	-10 to +50°C / 14 to 122°F
Accuracy	+/- 0.2% of full scale
Range (Max)	100 metres / 328 feet
Data Rate	1Hz
Protection	IP67 / NEMA6
Dimension A	164
	6.46
Dimension B	35
	1.38
Dimension C	85
	3.35
Dimension D	132
	5.20
Dimension ØE	13.2
	0.52
Dimension F	11
	0.43
Dimension G	28
	1.10
Recommended fittings	3/8" (10mm) G100 chain fittings

Grab Hooks:



A-1358 A-1338 L-1358 L-1338



GG GG LP

Chain shortener:



S-1311

Links:



A-1361 S-1370 MG

Lashing:



GT tensioner

Links:



S-1359 A-1339 S-1317



EGKN EGK GBK BKG

Connectors:



S-1325 CG CL

INSIGHT Software

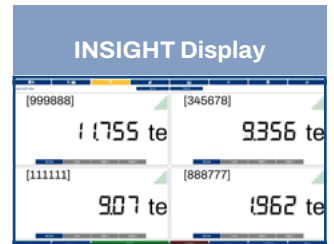
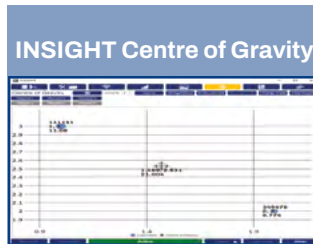
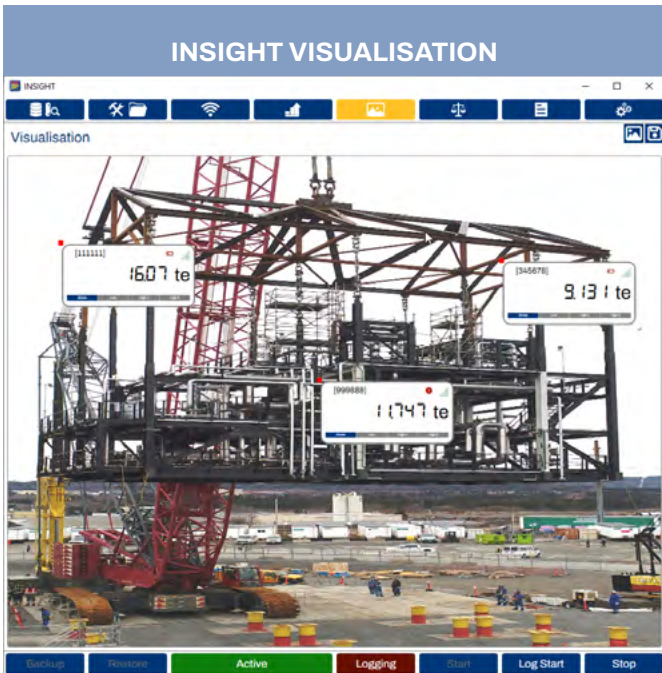

FEATURES AND BENEFITS

- Logging at timed intervals, manual or on overload/underload
- Log data at speeds up to 200Hz
- Visual and audible alarms indicate overload, underload, low battery and communications error
- 100% wireless, no easily damaged cables
- 700m or 2300ft range allows operator to stand at safe distance from test
- Connects to any Straightpoint wireless load cell
- Automatically creates digitally signed pass or fail certificate
- Real-time load v time graph display
- Three weighing's per C of G report with averages and statistical analysis to ISO19901
- Plot load cell positioning using measurements or GPS co-ordinates
- Free extra entry fields for operator, client, wind speed, sea states and temperature available for reporting
- Load cells may be split across several SW-D dongles for large scale projects

INSIGHT software, supplied with an SW-D USB wireless dongle, allows connection of up to 126 Straightpoint wireless load cells simultaneously onto any Windows tablet or laptop.

Insight has four main features:

- Multi-channel display and data logging mode
View and log load data from connected load cells plus totals loads live on screen and directly into a .csv file for later analysis at speeds of up to 200Hz.
- Visualisation mode
For complicated lifts import a photo of the lift and drag and drop load cell displays – make the screen look like the lift.
- Centre of gravity mode
Connect to SP's range of wireless compression load cells and use this feature to weigh and calculate the centre of gravity of large items and structures.
- Proof load testing
Real time graphing of load test and auto generated test certificates.

Numerous proof load testing applications worldwide require a load cell to verify the load applied. From crane testing, using water bags to pad eye testing, using hydraulic tools, the need to document test procedure and results has never been greater, especially as users of lifting equipment call for more traceability and audit trails.

A proof test is a form of stress test to demonstrate the fitness of a load-bearing structure, and is nominally a non-destructive test. Such a structure is often subjected to loads above that expected in normal use, demonstrating safety and design margin.

This demand has increased so much, Straightpoint offer a software package designed to connect to any of their wireless load cells - Proof Test plus.

This impressive package allows the test engineer to wirelessly, at a safe distance, monitor a proof load test and automatically create a pass or fail certificate when testing is complete.

The report is formatted as a PDF, which may then be printed, emailed or uploaded to the cloud, resulting in a traceable document for both test engineer and end customer.

Crosby | **SP**
know the load

Your Company Name
Address Line 1
Address Line 2
Address Line 3
Address Line 4
POST CODE
Phone Number
www.yoururl.com

Certificate of Load Test - 13/03/2020 10:13:49

Date of Test:	13/03/2020 10:13:49	Product Description:	dfs
Certification Number:	Required Prefix-10001	Serial or Tag No:	sdf
Company:	Test	WLL:	dsf
Address:	Test	Test Method:	sdfds
		Load Test To:	300te
Tel:	Test	Duration of Test:	33.59 seconds
Contact:	Test	Notes:	fsd
Reference Loadcell:	SIM1	Calibrated On:	Wednesday, 06 March 2019
Serial Number:	111111	WLL:	300
Calibrated Unit:	te	Measuring Unit:	te

Peak Load: 328.8 te

LOAD (te)

350
300
250
200
150
100
50
0

Time(s) 12.95 25.85

111111

This is to certify that this product described herein has been subjected to the load test.
Caution: Never exceed the rated capacities.

Notes: Test Notes Test Notes Test Notes Test Notes Test Notes Test Notes

Signed: Test

Appointed Person: Test ID: Test Test

Typical load tests using Straightpoint load cells include:

- Bollard pull tests
- Tug tests
- Crane Test (Water bags, block weights)
- Pad eye or fly point testing
- Crash barrier testing
- Lifting equipment testing
 - Slings, chains, wire rope, hooks
- Construction equipment testing
 - Shoring columns, acrow props and lintels
- Lifting and spreader beam testing
- Hydraulic cylinder load test
- Supplied with SW-D transmitter

SP Model	INSIGHT
Crosby Part	2789318
USB Dongle Operating temperature	-20°C to 70°C / -4°F to 158°F
Licence	RF Band Licence free
Wireless Frequency	2.4GHz
Wireless Range (Max)	700m / 2300 ft
Loadcell inputs	Up to 126
PC requirements	Intel i5 processor with 8Gb RAM
Operating system	Windows 10, Windows 11

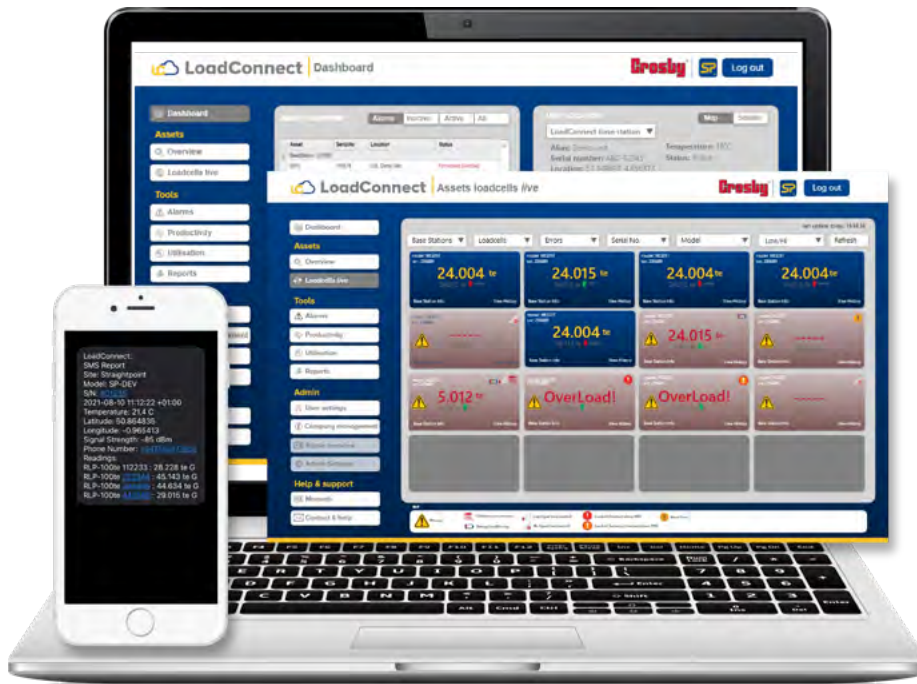

Record live loadcell data from worksites using LoadConnect, a comprehensive cloud-based online dashboard that connects to either the WiFi version LCBS-W base station or the 3G/4G Network version LCBS-N base station transmitting data via a cellular micro sim card.

A solution to monitor loads and line tensions from anywhere in the world and at multiple locations. Stay connected, improve safety and efficiency by permanently and wirelessly transmitting live data to a comprehensive data suite.

The cloud dashboard data will enhance productivity and efficiency at facilities, factories, shipbuilding yards or construction sites where detailed logging and reporting of load cell (crane) productivity, safety alerts, and throughput is required.

FEATURES

- Dashboard overview
- Live load data
- Error and condition reporting
- Productivity and utilisation graphs
- Regular email reporting
- Connect to BOLT to monitor tension on cables
- Connect to SP loadcells to monitor loads

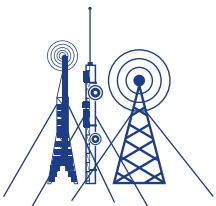

BENEFITS

- Cloud-based solution to monitor loads from anywhere in the world
- Improve worksite safety with real time load data
- Reduce site visits to remote sites
- Improve productivity by data analysis
- Faster reaction and collaboration
- Protect assets such as cranes and product
- Monitor lifting projects from across the globe





SP Model	LCBS-N	LCBS-W
Crosby Part	2789574	2789596
Required Power Supply	9 to 28 V DC	9 to 28 V DC
Radio frequency	2.4 GHz (License Free)	2.4 GHz (License Free)
Maximum number of Loadcells	16 wireless (or 15 wireless & 1 cabled)	16 wireless (or 15 wireless & 1 cabled)
Range	Up to 500 m / 1640 ft	Up to 500 m / 1640 ft
Operating temperature	-10 to +50 °C / 14 to 122°F	-10 to +50 °C / 14 to 122°F
Backup battery life	8 hours	8 hours
Input option	1x 4-20mA (2 wire) OR 1x mV/V	1x 4-20mA (2 wire) OR 1x mV/V
Weight	2.75 kg / 6lbs	2.75 kg / 6lbs
Network supported	3G/4G	2.4GHz WiFi
Frequency band	LTE-TDD B34/B38/B39/B40/B41 LTE-FDD B1/B2/B3/B4/B5/B7/B8/B12/B13/ B18/B19/B20/B25/B26/B28/B66 UMTS/HSPA+ B1/B2/B4/B5/B6/B8/B19	NA
SIM type	Micro SIM (not included)	NA
Alert functionality	via SMS (up to 3 pre-defined numbers)	Subscription to online dashboard only (No SMS Alerts)
IP Rating	IP67/NEMA6	IP67/NEMA6
Dimension	560 x 260 x 90 mm / 22" x 10.2" x 3.5" - antennas included	560 x 260 x 90 mm / 22" x 10.2" x 3.5" - antennas included

Data option to be enabled on the SIM card used for full functionality

User configuration is required via free software supplied



Wireless Accessories

Crosby Straightpoint's range of wireless accessories may be used with any Crosby Straightpoint wireless load cell



Wireless overload alarm module Part N°s **SP** SW-OAM **Crosby** 2789129

This wireless relay module features audio and visual warning indicators. The alarm can be triggered based on the set alarm level of individual Crosby Straightpoint loadcells. It contains two relays (NO and NC). NO is for audio and visual indications, while NC is a spare and can be used to control 230V AC / 30VDC 5A systems.



Wireless scoreboard display Part N°s **SP** SW-SD **Crosby** 2789132

This 100mm or 4" scoreboard LED display is wireless and operates between 100-240V AC. The numerals are viewable for up to 45m or 150ft, making it perfect for installation on a crane gantry. The SW-SD displays an individual load in tonnes or summed load of up to four Crosby Straightpoint wireless devices.



Wireless analogue output Part N°s **SP** SW-BS **Crosby** 2789314

The SW-BS provides a configurable analogue output for any single or summed group of up to 4 Crosby Straightpoint wireless load cells and is ideal for integration to a PC, PLC and other data acquisition. Housed in a IP65 enclosure, the output can be selected from Current 4-20mA, 2 Relay Outputs, RS485 ASCII (Configurable) plus an optional CANbus 2.0A or 2.0B output.



Wireless Load Cell Transmitter Part N°s **SP** SA700C **Crosby** 2789097

The SA700C transmitter connects to strain gauge transducers such as load cells, torque sensors and pressure transducers allowing them to form part of a Crosby Straightpoint wireless system. Load data from the SA700C can be received by multiple receivers that include SW-HHP handheld, INSIGHT software or Crosby Straightpoint's range of wireless accessories.



Wireless Load Cell Signal Booster Part N°s **SP** SW-R **Crosby** 2789732

Crosby Straightpoint Wireless Signal Booster (SW-R) improves the signal from wireless load cells to either a handheld display or Insight software when there are obstacles in the line of the wireless transmission.

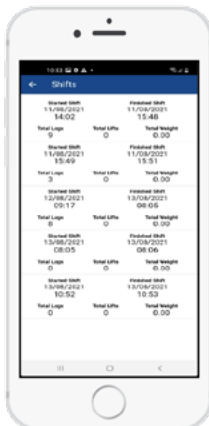
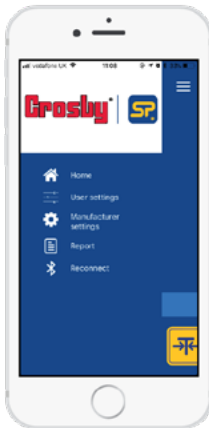

Up to four Crosby Straightpoint, Bluetooth load cells can be connected and monitored by up to eight smartphones, with the HHP2 app installed. It will enable more than one lifting professional to monitor the loads progress and safety, spotting potential dangers or issues from different vantage points.

The HHP2 app's simple and easy-to-use interface will enable the operator to use the app with the utmost efficiency. There are five different measurement units to choose from - tonnes, lbs, kN, kg and a custom unit.

The app records total loads, weights and lifts. This feature is useful when a particular measurement(s) is required for later referral. Added to this is the option to set the threshold and measure productivity for each load cell and the device it's rigged to, a crane, for instance, for analysis to see shortfalls and improve performance.

A peak facility can be activated to display the highest force measured alongside the live load reading of four load cells simultaneously plus a total load.

Once measurements are recorded to the app using the load monitoring project record and data log feature, the operator can export the details. The report will include load, time and date, GPS coordinates and project information to either a mobile device or send it to a particular email address in csv format.

FEATURES AND BENEFITS

- Connect up to four load cells simultaneously
- Set lift threshold and measure productivity per shift
- View in eight different languages
- Overload screen flash option
- Alarm latching
- Set and record overload incidents
- Up to 100m or 328ft Bluetooth monitoring distance
- Multiple weight unit measurement options (kN, metric tons, kg, lbs, custom unit)
- Peak hold and display value alongside live readings
- Datalog Report
- Export Datalog Report
- Zero and gross monitoring options
- User defined resolution setup

Handheld plus



FEATURES & BENEFITS

- Displays up to 4 loadcells simultaneously
- Wireless range 1000m or 3280ft (ATEX 500m or 1640ft)
- Low battery warning
- Signal strength warning
- Overload counter
- User settable 90db audible overload alarm
- Multiple display units – tonnes, lbs, kg and kN
- 200Hz Peak hold

The Handheld plus is a rugged and versatile digital handheld display. It has an extensive range of features and is suitable for all Crosby|SP load cell products.

At the heart of the ergonomically designed Handheld plus is a powerful PCB providing industry leading features such as user selectable units of measure (tonnes, lbs, kg and kN), programmable audible overload alarm (HHP & SW-HHP), peak hold, pre-set tare and a user resettable (HHP & SW-HHP) overload counter.

This crucial overload alarm counter is a requirement for many safety and quality control departments, as it keeps track of overload events, allowing the load cell in question to be removed from service immediately, following the calibration voiding overload event. The load cell in question can then be sent out for proper testing and, if necessary, recalibration before re-entering service.

The HHP is suitable for connection via cable to any Straightpoint cabled load cell product and easily adapted to any other manufacturers' load cell product with a mv/v output.

In addition to the standard HHP the SW-HHP is suitable for connection to any Straightpoint wireless load cell, has a range of up to 1000m/3280ft (ATEX 500m/1640ft) and is supplied as standard with the Radiolink plus load cell.

SP Model	HHP	SW-HHP	SW-HHP ATEX
Part Number	2789030	2789126	2789442
Battery Type	2 x AA		2x AA Energizer L91
Battery Life	100 hrs continuous	40 hrs continuous	40 hrs continuous
Display Type	240x128 multi-line dot matrix with backlight		240x128 multi-line dot matrix
Audible Alarm	Yes	Yes	No
Operating Temp	-10 to +50 °C / 14 to 122 °F		
Protection	IP65 / NEMA 4X		
Excitation	3.3V	N/A	
Max Sensitivity	3mV/V		
Range (Max)	N/A	1000m or 3280ft	500m or 1640ft
Connectivity	6-way female binder 723 socket	Wireless 2.4 GHz	Wireless 2.4 GHz
Loadcells	1	4	4

Also available with hazardous area approval



ATEX / IECEx
Ex ia II CT4 Ga

Certification number:

SW-HHP ATEX

IECEx SIR 15.0072X / SIR 15ATEX2196X / CSAE 22UKEX1267X

When ordering ATEX/IECEx version of SW-HHP, order using code: SW-HHP-ATEX

Please note: There is no audible alarm with ATEX



Wall or Cab Mount Bracket Part N°s **SP** SU3282 **Crosby** 2789228

Constructed from stainless steel and fitted with a viewing angle adjusting mechanism, the SU3282 bracket fits either the HHP or SW-HHP handheld displays. Ideal for wall or cab mounting, leaving the operators to work safely, hands free.



External Amplifier Part N°s **SP** SA-3420 **Crosby** 2789096

The SA-3420 external amplifier allows the operator to convert the output of any of the SP cabled load cell products into a three wire 4-20mA analogue output. The weatherproof enclosure is fitted with stainless steel glands and is suitable for connection to a PLC, data logger or other instrumentation.



Handheld Rubber Boot Part N°s **SP** SU4045 **Crosby** 2789232

Drop tested to one metre at -30°C , this 70SHA rubber boot is purpose moulded to fit and protect the HHP and SW-HHP handheld display against impact, especially when it is used in the harshest industrial environments.

Subsea Link

SP's Subsea link (SL) has been manufactured for use in subsea or submersible projects where accurate load monitoring is required.

Constructed from 17-4PH stainless steel with o'ring seals and moulded SubConn connector the SL link design ensures high integrity and will resist saltwater, temperature variations and the water pressure at varying depths of up to 2000m or 6562 feet.

At depth the SL can be handled and rigged via an ROV where it maybe inaccessible by a diver/s or cost may prohibit.

Output options include mV/V to the SP Handheld plus, 4-20mA or 0-10v analog to a PLC, Datalogger or The Multi Operation Survey System (MOSS), RS485 or an integral datalogger storing up to one million readings and powered by an internal battery.

Designed to accept Crosby ROV shackles - additionally there is an option for ROV mounting on the SL body itself.

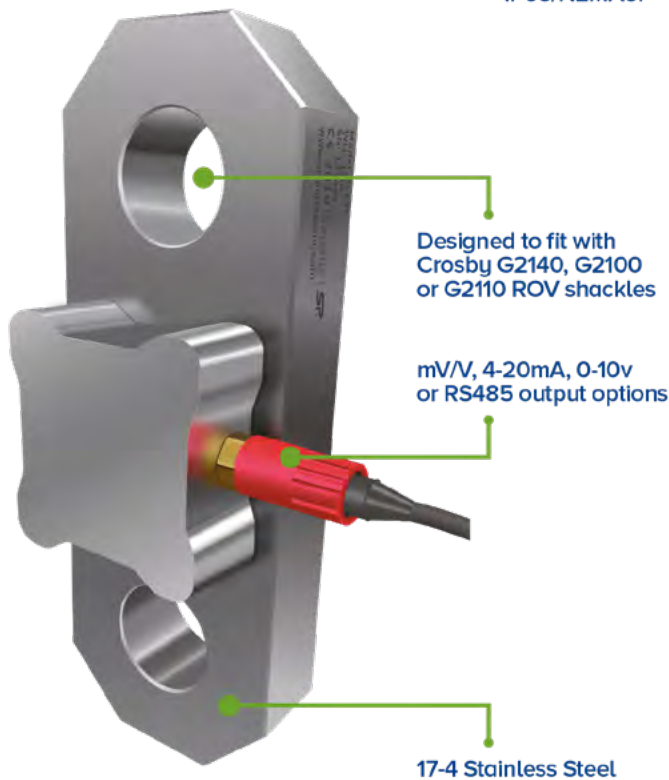
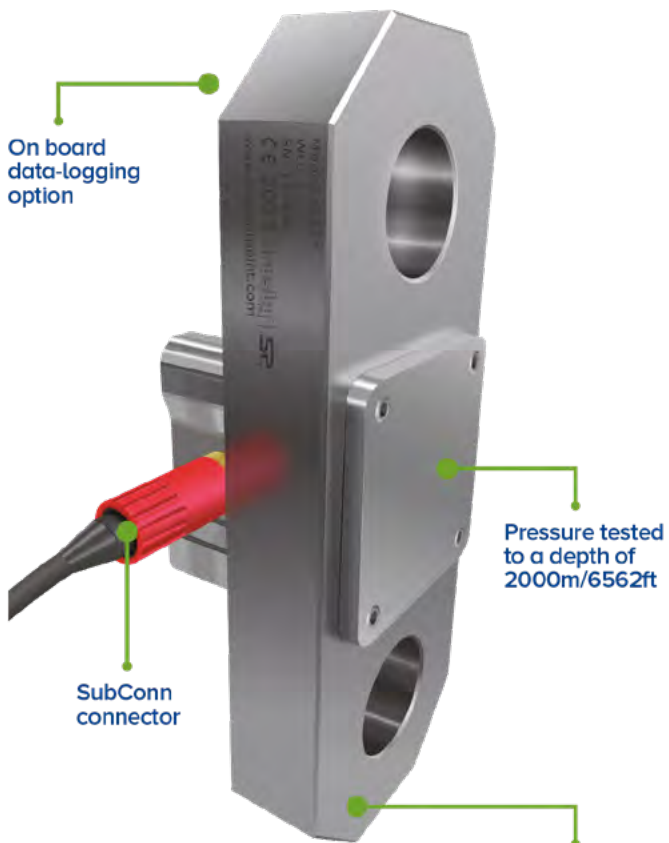

FEATURES AND BENEFITS

- On board data-logging option
- Pressure tested to depth of 2000m/6562ft
- SubConn connector
- Environmental protection IP68/NEMA6P
- mV/V, 4-20mA, 0-10v, RS485 output options
- 17-4 Stainless Steel
- Designed to fit with Crosby ROV shackles

APPLICATIONS

- Offshore platforms
- Ships and towing cables
- Aquaculture
- Subsea structure lifting systems
- ROV exploration
- Umbilical load monitoring
- Oceanography or navigation projects
- Renewable energy platforms

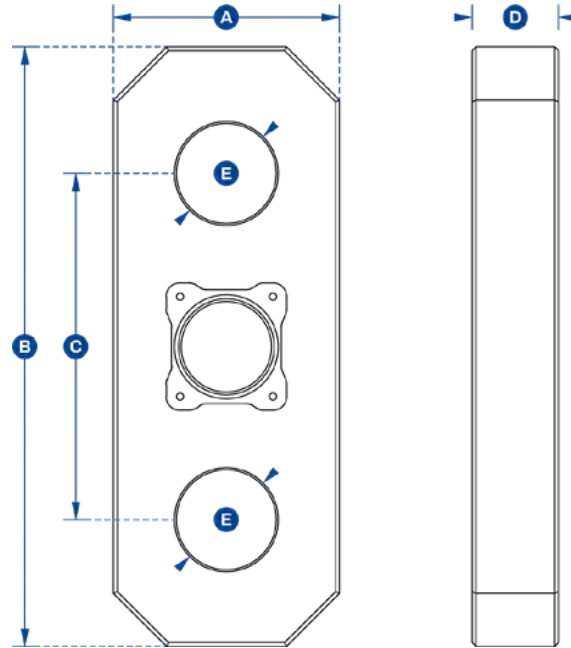

SP Model	SL6T5	SL12T	SL25T	SL35T	SL55T	SL85T	SL120T
Crosby Part	2789352	2789353	2789354	2789355	2789356	2789357	2789358
Capacity	6.5 te	12 te	25 te	35 te	55 te	85 te	120 te
	14,300 lb	26,000 lb	55,000 lb	77,000 lb	120,000 lb	185,000 lb	260,000 lb
Weight	7 kg	10 kg	16 kg	22 kg	34 kg	46 kg	67 kg
	15 lb	23 lb	34 lb	49 lb	75 lb	101 lb	148 lb
Safety Factor	5:1						
Output	Options for: mV/V, 4-20mA, 0-10v, RS485 or internal data logger						
Operating Temp	-10 to +50 °C / 14 to 122°F						
Accuracy	+/- 0.1% FS						
Max depth of use	2000 meters/ 6562 feet						
Material	17-4PH stainless steel						
MTBF to WLL	Typically 50 million cycles						
Elongation	Typically <0.4 mm at WLL						
Dimension A	95	100	130	150	168	190	220
	3.74	3.94	5.12	5.91	6.61	7.48	8.66
Dimension B	240	300	350	400	450	490	550
	9.45	11.81	13.78	15.75	17.72	19.29	21.65
Dimension C	180	200	230	250	260	290	335
	7.09	7.87	9.06	9.84	10.24	11.42	13.19
Dimension D	25	40	45	50	65	75	86
	0.98	1.57	1.77	1.97	2.56	2.95	3.39
Dimension ØE	30	40	55	60	75	88	100
	1.18	1.57	2.17	2.36	2.95	3.46	3.94
Dimension F	73	88	93	98	113	123	134
	2.87	3.46	3.66	3.86	4.45	4.84	5.28
Crosby Shackle	G2130	G2130 or G2100 or G2110 ROV shackles			G2140 or G2100 or G2110 ROV shackles		G2140

Loadlink plus



Known worldwide as the original electronic force measurement device to feature an integral display, the Loadlink plus has been in production since 1979. Over the years, the line has been expanded and it is now used on a daily basis for load monitoring and heavy lifts. These can range in capacity from 1t to 300t, and are used by a variety of industrial and commercial industries including manufacturing, transportation, agriculture, oil and gas, utilities, aerospace and clean energy.

This latest version of the well-known product has advanced features and benefits, providing solutions for today's complicated load test and force monitoring needs. The Loadlink plus features full function push button controls for tare, choice of units (lbs, kg, kN and tonnes), peak hold, preset tare, audible set-point alarm and an overload counter.

The advanced microprocessor-based electronics provide the Loadlink plus with high speed read rates, extreme resistance to industrial level noise and unprecedented stability. This high stability gives the Loadlink plus over 5,000 divisions and the highest standard resolution of any digital dynamometer on the market today. Constructed of high-grade aircraft quality aluminium, Straightpoint's advanced internal design structure allows the product to once again top the charts with an unmatched weight to strength ratio. Straightpoint's link style dynamometers are on average 30% lighter than their closest competitor with the same safety rating.



Optional Connection
to SP's Handheld plus
SP Crosby
Part Nos.
T24 HHP
2789030

FEATURES AND BENEFITS

- Large 25mm or 1" LCD display
- High accuracy
- Selectable units t, lbs, kN & kg
- High resolution
- 100Hz Peak hold
- Push button tare
- Light weight
- Preset tare
- Overload counter
- 90db Audible set point alarm
- RS-485 serial output
- Design validated by F.E.A.
- 2-year warranty
- DNV-GL Type Approval
- Complies with ASME B30.26

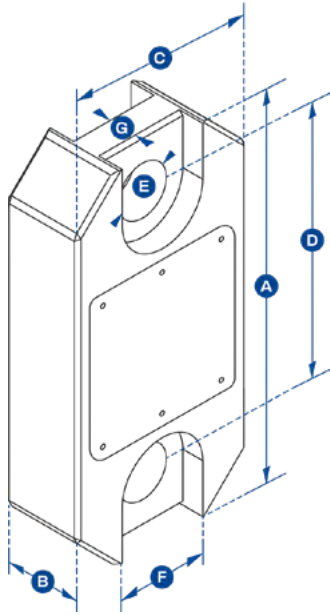

SP Model	LLP1T	LLP2T5	LLP6T5	LLP12T	LLP25T	LLP35T	LLP55T	LLP75T	LLP100T	LLP150T	LLP200T	LLP250T	LLP300T
Crosby Part	2789042	2789046	2789050	2789040	2789045	2789048	2789049	2789051	2789039	2789041	2789043	2789044	2789047
Capacity	1,000 kg	2.5 te	6.5 te	12 te	25 te	35 te	55 te	75 te	100 te	150 te	200te	250 te	300 te
	2,200 lb	5,500 lb	14,300 lb	26,000 lb	55,000 lb	77,000 lb	120,000 lb	165,000 lb	220,000 lb	330,000 lb	440,000 lb	550,000 lb	660,000 lb
Resolution	0.5 kg	0.001 te	0.001 te	0.002 te	0.005 te	0.005 te	0.01 te	0.01 te	0.05 te	0.05 te	0.1 te	0.1 te	0.1 te
	1 lb	2 lb	2 lb	5 lb	10 lb	10 lb	20 lb	20 lb	100 lb	100 lb	200 lb	200 lb	200 lb
Units	te, lb, kg, kN												
Weight	1.5 kg	1.5 kg	2.4 kg	3.7 kg	5 kg	8.6 kg	13 kg	16 kg	34 kg	46 kg	82 kg	82 kg	118 kg
	3.3 lb	3.3 lb	5.3 lb	8.2 b	11 lb	19 lb	28.7 lb	35.3 lb	75 lb	101.4 lb	180.8 lb	180.8 lb	260 lb
Safety Factor	12.1	7:1	7:1	7:1	5:1	5:1	5:1	5:1	5:1	4:1	5:1	4:1	5:1
Protection	IP65 / NEMA 4X												
Battery Type	9v PP3												
Battery Life	80 hrs continuous												
Display Type	6 digit 25 mm LCD / 6 digit 1 in LCD												
Operating Temp	-10 to +50 °C / 14 to 122°F												
Accuracy	+/- 0.1% FS												
Dimension A	204	204	249	305	340	393	424	470	608	670	700	700	806
	8.03	8.03	9.80	12.01	13.39	15.47	16.69	18.50	23.94	26.38	27.56	27.56	31.73
Dimension B	43	43	43	47	60	75	75	75	99	99	144	144	150
	1.69	1.69	1.69	1.85	2.36	2.95	2.95	2.95	3.90	3.90	5.67	5.67	5.91
Dimension C	104	104	113	113	115	126	180	202	255	303	350	350	426
	4.09	4.09	4.45	4.45	4.53	4.96	7.09	7.95	10.04	11.93	13.78	13.78	16.77
Dimension D	146	146	165	193	215	225	230	260	320	360	350	350	350
	5.75	5.75	6.50	7.60	8.46	8.86	9.06	10.24	12.60	14.17	13.78	13.78	13.78
Dimension Ø E	24.5	24.5	38	47.5	55	60	76	76	109	109	145	145	160
	0.96	0.96	1.50	1.87	2.17	2.36	2.99	2.99	4.29	4.29	5.71	5.71	6.30
Dimension F	48	48	66	66	66	66	66	66	66	66	66	66	66
	1.89	1.89	2.60	2.60	2.60	2.60	2.60	2.60	2.60	2.60	2.60	2.60	2.60
Dimension G	19	19	32	32	32	32	32	32	32	32	32	32	32
	0.75	0.75	1.26	1.26	1.26	1.26	1.26	1.26	1.26	1.26	1.26	1.26	1.26
Crosby Shackle	G2130	G2130	G2130	G2130	G2130	G2130	G2140	G2140	G2140	G2140	G2140	G2140	G2140
Loading Pin Ø	19	19	25	35	51	57	57	70	83	95	121	127	152
	3/4 in	3/4 in	1 in	1 3/8 in	2 in	2 1/4 in	2 1/4 in	2 3/4 in	3 1/4 in	3 3/4 in	4 3/4 in	5 in	6 in

Wirelink plus



The Wirelink plus is the non-indicating version of Crosby Straightpoint's very popular Radiolink plus and Loadlink plus digital dynamometer tension load cells. This non-indicating Loadlink is designed for use with Crosby Straightpoint's Handheld plus digital display.

Manufactured from aerospace grade aluminium, utilising an advanced internal design structure, this range of non-indicating load cells are extremely lightweight, easy to handle and are used worldwide in an array of industries for lifting, pulling, proof and structural load testing.

The extremely versatile platform can be used with digital displays, including the Crosby Straightpoint Handheld plus, PLCs, data acquisition systems (DAQ) etc. They are configured with a vast array of output formats to include mV/V, RS-422, RS-485, utilising the ASCII, MODBUS RTU and CAN-BUS protocols.

A standard analogue output option is available to include:

- 3 wire 0-10v
- 3 wire 0-5v
- 4 wire +/-10v
- 3 wire 4-20mA
- 2 wire 4-20mA

The Wirelink plus is supplied with a 10-metre cable as standard, however, usable cable length varies greatly with lengths available to 1,500 metres depending on output format.

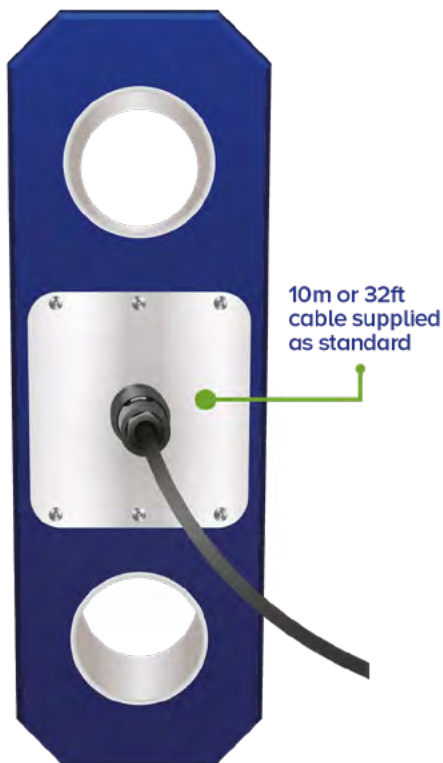

FEATURES AND BENEFITS

- Constructed of lightweight aluminium
- Available in capacities ranging from 1 to 300 tonnes
- High accuracy
- Multiple output options to include mV/V, analogue out, ASCII, MODBUS RTU and CAN-BUS
- Available with IP68 environmental protection
- Options for subsea use available
- 2-year warranty
- DNV-GL Type Approval
- Complies with ASME B30.26

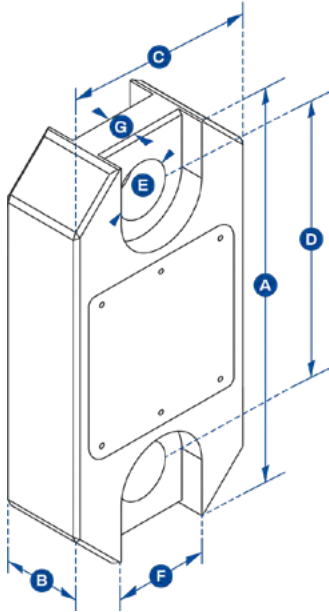

SP Model	WLP1T	WLP2T5	WLP6T5	WLP12T	WLP25T	WLP35T	WLP55T	WLP75T	WLP100T	WLP150T	WLP200T	WLP250T	WLP300T
Crosby Part	2789154	2789158	2789273	2789152	2789157	2789160	2789269	2789161	2789151	2789153	2789155	2789156	2789159
Capacity	1,000 kg	2.5 te	6.5 te	12 te	25 te	35 te	55 te	75 te	100 te	150 te	200 te	250 te	300 te
	2,200 lb	5,500 lb	14,300 lb	26,000 lb	55,000 lb	77,000 lb	120,000 lb	165,000 lb	220,000 lb	330,000 lb	440,000 lb	550,000 lb	660,000 lb
Resolution	0.5 kg	0.001 te	0.001 te	0.002 te	0.005 te	0.005 te	0.01 te	0.01 te	0.05 te	0.05 te	0.1 te	0.1 te	0.1 te
	1 lb	2 lb	2 lb	5 lb	10 lb	10 lb	20 lb	20 lb	100 lb	100 lb	200 lb	200 lb	200 lb
Weight	1.5 kg	1.5 kg	2.4 kg	3.7 kg	5 kg	8.6 kg	13 kg	16 kg	34 kg	46 kg	82 kg	82 kg	118 kg
	3.3 lb	3.3 lb	5.3 lb	8.2 lb	11 lb	19 lb	28.7 lb	35.3 lb	75 lb	101.4 lb	180.8 lb	180.8 lb	260 lb
Safety Factor	12.1	7:1	7:1	7:1	5:1	5:1	5:1	5:1	5:1	4:1	5:1	4:1	5:1
Protection	IP67 / NEMA6												
Operating Temp	-10 to +50 °C / 14 to 122°F												
Accuracy	+/- 0.1% FS												
Dimension A	204	204	249	305	340	393	424	470	608	670	700	700	806
	8.03	8.03	9.80	12.01	13.39	15.47	16.69	18.50	23.94	26.38	27.56	27.56	31.73
Dimension B	43	43	43	47	60	75	75	75	99	99	144	144	150
	1.69	1.69	1.69	1.85	2.36	2.95	2.95	2.95	3.90	3.90	5.67	5.67	5.91
Dimension C	104	104	113	113	115	126	180	202	255	303	350	350	426
	4.09	4.09	4.45	4.45	4.53	4.96	7.09	7.95	10.04	11.93	13.78	13.78	16.77
Dimension D	146	146	165	193	215	225	230	260	320	360	350	350	350
	5.75	5.75	6.50	7.60	8.46	8.86	9.06	10.24	12.60	14.17	13.78	13.78	13.78
Dimension ØE	24.5	24.5	38	47.5	55	60	76	76	109	109	145	145	160
	0.96	0.96	1.50	1.87	2.17	2.36	2.99	2.99	4.29	4.29	5.71	5.71	6.30
Dimension F	48	48	65	Not relevant in this capacity									
	1.89	1.89	2.60										
Dimension G	19	19	32										
	0.75	0.75	1.26										
Crosby Shackle	G2130	G2130	G2130	G2130	G2130	G2130	G2140	G2140	G2140	G2140	G2140	G2140	G2140
Loading Pin Ø	19	19	25	35	51	57	57	70	83	95	121	127	152
	3/4 in	3/4 in	1 in	1 3/8 in	2 in	2 1/4 in	2 1/4 in	2 3/4 in	3 1/4 in	3 3/4 in	4 3/4 in	5 in	6 in

Part Number	ICA1	ICA2	ICA3	ICA4	ICA5
Crosby Part	2789220	2789221	2789222	2789223	2789224
Description	3 wire 0-10v analogue output	3 wire 0-5v analogue output	4 wire +/- 10v analogue output	3 wire 4-20mA analogue output	2 wire 4-20mA analogue output

Loadshackle

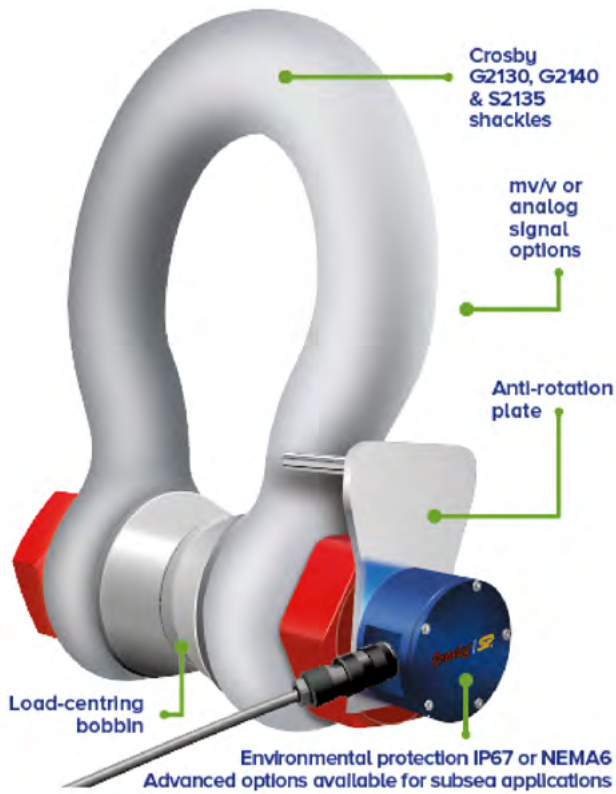

FEATURES AND BENEFITS

- Robust construction
- Compact size and low headroom
- Every Loadshackle proof tested
- Lightweight
- Unrivalled resolution
- Environmentally sealed to IP67 or NEMA6
- Advanced options available for subsea applications
- Manufactured using industry leading brand shackles
- mv/v or analog signal options
- Design validated by F.E.A.

Straightpoint's Loadshackle is available from stock in capacities of 3.25t to 400t, as well as being obtainable up to 3000t.

Manufactured from Crosby's industry-leading G-2130 Carbon and G-2140 Alloy Bolt Type Anchor Shackle, the product offers reduced overall weight and headroom, providing a great fit for low headroom applications.

Utilising the same advanced microprocessor based electronics as all Straightpoint products, the cabled Loadshackle benefits from high sampling rates, extreme resistance to industrial level noise and unprecedented stability.

A huge range of tooling allows Straightpoint to calibrate in shackle for extra accuracy, unlike many other load cell manufacturers. Their cabled Loadshackles are also in capacities of 3.25t to 400t, as well as being obtainable up to 3000t.

Manufactured from Crosby's industry-leading 2130 Carbon and 2140 Alloy Bolt Type Anchor Shackle, the product offers reduced overall weight and headroom, providing a great fit for low headroom applications.

Utilising the same advanced microprocessor based electronics as all Straightpoint products, the cabled Loadshackle benefits from high sampling rates, extreme resistance to industrial level noise and unprecedented stability.

A huge range of tooling allows Straightpoint to calibrate in shackle for extra accuracy, unlike many other load cell manufacturers. Their cabled Loadshackles are also environmentally sealed to IP67 or NEMA6 and, as an option, sealed for permanent submersion for sub-sea use.

The cabled Loadshackle range can be used with digital displays, including the Straightpoint Handheld plus, PLCs, data acquisition systems (DAQ), etc.

They are configured with a vast array of output formats to include mV/V, RS-422, RS-485, utilising the ASCII, MODBUS RTU and CAN-BUS protocols or supplied with integral amplifier allowing analogue outputs such as 4-20mA, 0-10v, 0-5v etc.

Whether used in heavy lifting, mooring anchor placement or sub-sea applications, Straightpoint's cabled Loadshackle offers robust construction, advanced electronics, industry leading resolution and accuracy - all at a cost-effective, affordable price.

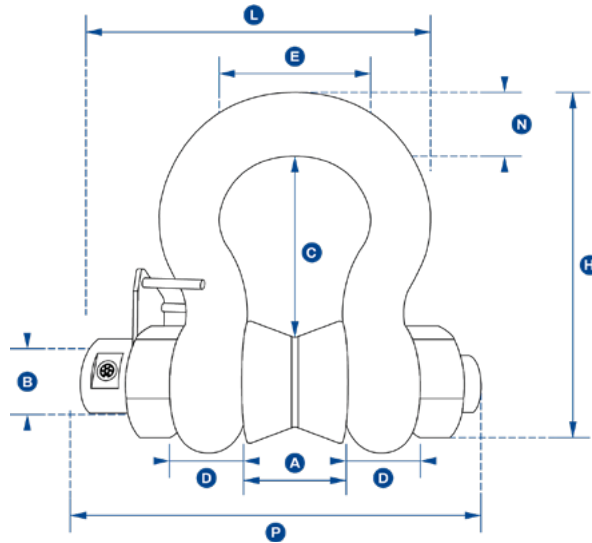

SP Model	SLB3.25T	SLB6.5T	SLB12T	SLB25T	SLB55T	SLB85T	SLB120T	SLB200T	SLB300T	SLB400T
Crosby Part	2789106	2789111	2789103	2789105	2789110	2789112	2789102	2789104	2789107	2789108
Capacity	3.25te	6.5te	12te	25te	55te	85te	120te	200te	300te	400te
	7150lb	14300lb	26400lb	55000lb	120000lb	185000lb	260000lb	440000lb	660000lb	880000lb
Resolution	0.005te	0.005te	0.01te	0.02te	0.05te	0.05te	0.1te	0.2te	0.5te	0.5te
	10lb	10lb	20lb	50lb	100lb	100lb	200lb	200lb	1000lb	1000lb
Weight	2.8kg	3.2kg	8kg	18kg	25kg	85kg	125kg	260kg	405kg	662kg
	6.16lb	7lb	17.6lb	40lb	55lb	187lb	276lb	573lb	893lb	1459lb
Protection	IP67 / NEMA6									
Safety Factor	5:1 when used with bobbin									
Operating Temp	-10 to +50 °C / 14 to 122°F									
Accuracy	+/- 1% FS									
Dimension A	26.9	36.6	51.5	73	82.5	127	144	180	205	230
	1.06	1.44	2.03	2.87	3.25	5.00	5.66	7.09	8.07	9.06
Dimension ØB	19.1	25.4	35.1	51	57	83	95	125	150	175
	0.75	1.00	1.38	2.01	2.24	3.26	3.74	4.92	5.91	6.89
Dimension C	56.9	79.7	113	170	189.5	317	364	432.2	505	547.7
	2.24	3.14	4.45	6.69	7.46	12.48	14.33	17.02	19.88	21.56
Dimension D	14.46	20.6	29.5	44.5	51	80	89	110	120	160
	0.57	0.81	1.16	1.75	2.01	3.14	3.50	4.33	4.72	6.30
Dimension E	42.9	58	82.5	127	146	190	238	280	305	325
	1.69	2.28	3.25	5.00	5.75	7.48	9.37	11.02	12.01	12.80
Dimension H	106	148	210	313	348	539	624	769	904	1006.5
	4.17	5.83	8.27	12.32	13.70	21.22	24.56	30.28	35.59	39.63
Dimension L	125	146.5	191	265	296	384	434	519.7	576.7	657.2
	4.92	5.77	7.52	10.43	11.65	15.11	17.12	20.46	22.70	25.87
Dimension N	17.5	24.6	35.1	57	61	85	95	120	140	160
	0.69	0.97	1.38	2.24	2.40	3.34	3.74	4.72	5.51	6.30
Dimension P	140	163	212	280	307	438	478	590	647	755
	5.51	6.42	8.35	11.02	12.09	17.24	18.81	23.23	25.47	29.72
Crosby Shackle	G2130				G2140	S2135				

Compression Loadcell

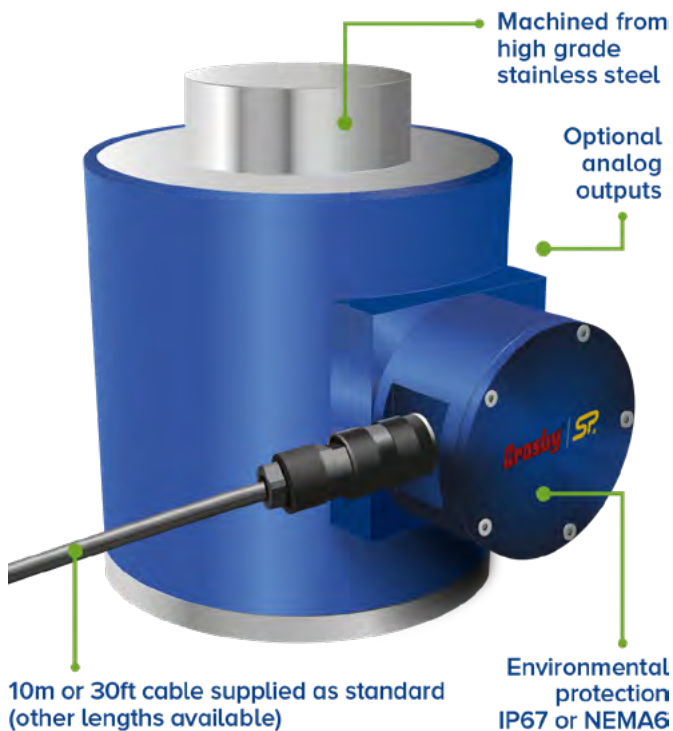

FEATURES AND BENEFITS

- Compact size
- Environmentally sealed to IP67 or NEMA6
- Optional analogue outputs
- Stainless steel element
- High accuracy
- Lightweight
- Unrivalled resolution
- 10m or 30ft cable supplied as standard (other lengths available)
- Custom versions available
- Design validated by F.E.A.

Manufactured in ranges from 5te to 1000te - other capacities available on application.

Straightpoint compression load cells are manufactured to the same stringent standards as all Straightpoint products.

The bodies are machined from high grade stainless steel, offering excellent strength and anti-corrosion properties. Compression load cells can be supplied with optional loadcaps to protect objects being tested.

The compact lightweight design provides ease of use and superior portability, allowing Straightpoint compression load cells to be used in a broad range of industries including mining, energy, defence, heavy rigging, shipping and general transportation sectors.

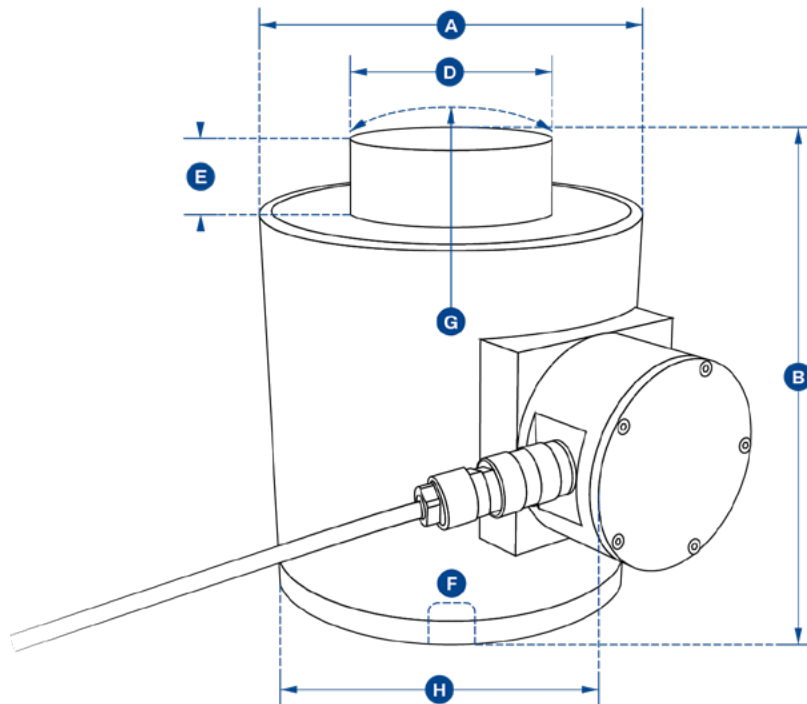

SP Model	NI5TC	NI10TC	NI25TC	NI50TC	NI100TC	NI150TC	NI300TC	NI500TC	NI1000TC
Crosby Part	2789068	2789062	2789065	2789067	2789061	2789063	2789064	2789066	2789275
Capacity	5 te	10 te	25 te	50 te	100 te	150 te	300 te	500 te	1,000 te
	11,000 lb	22,000 lb	55,000 lb	110,000 lb	220,000 lb	330,000 lb	660,000 lb	110,0000 lb	2,200,000 lb
Resolution	0.001te	0.002 te	0.005 te	0.01 te	0.05 te	0.05 te	0.1 te	0.2 te	0.5 te
	2 lb	5 lb	10 lb	20 lb	100 lb	100 lb	200 lb	500 lb	1,000 lb
Weight	6.2 kg	6.2 kg	6.2 kg	6.2 kg	15.5 kg	15.5 kg	65 kg	65 kg	172 kg
	13.64 lb	13.64 lb	13.64 lb	13.64 lb	34 lb	34 lb	143 lb	143 lb	379 lb
Safety Factor	3:1								
Protection	IP67/NEMA6								
Operating Temp	-10 to +50 °C / 14 to 122°F								
Accuracy	+/- 0.1% FS								
Dimension ØA	100	100	100	100	152	152	185	185	362
	3.94	3.94	3.94	3.94	5.98	5.98	7.28	7.28	14.25
Dimension B	127	127	127	127	184	184	300	300	310
	5.00	5.00	5.00	5.00	7.24	7.24	11.81	11.81	12.20
Dimension ØD	59	59	59	59	80	80	155	155	270
	2.32	2.32	2.32	2.32	3.15	3.15	6.10	6.10	10.63
Dimension E	16	16	16	16	26	26	27.5	27.5	40
	0.63	0.63	0.63	0.63	1.02	1.02	1.08	1.08	1.57
Dimension F	M18 x 2.5	M18 x 2.5	M18 x 2.5	M20 x 2.5	M20 x 2.5	M20 x 2.5	M20 x 2.5	M20 x 2.5	M30x3.5
	M18 x 2.5	M18 x 2.5	M18 x 2.5	M20 x 2.5	M20 x 2.5	M20 x 2.5	M20 x 2.5	M20 x 2.5	M30x3.5
Dimension G	152	152	152	152	432	432	432	432	950
	5.98	5.98	5.98	5.98	17.01	17.01	17.01	17.01	37.40
Dimension H	158	158	158	158	204	204	237	237	416
	6.22	6.22	6.22	6.22	8.03	8.03	9.33	9.33	16.38

Loadpin

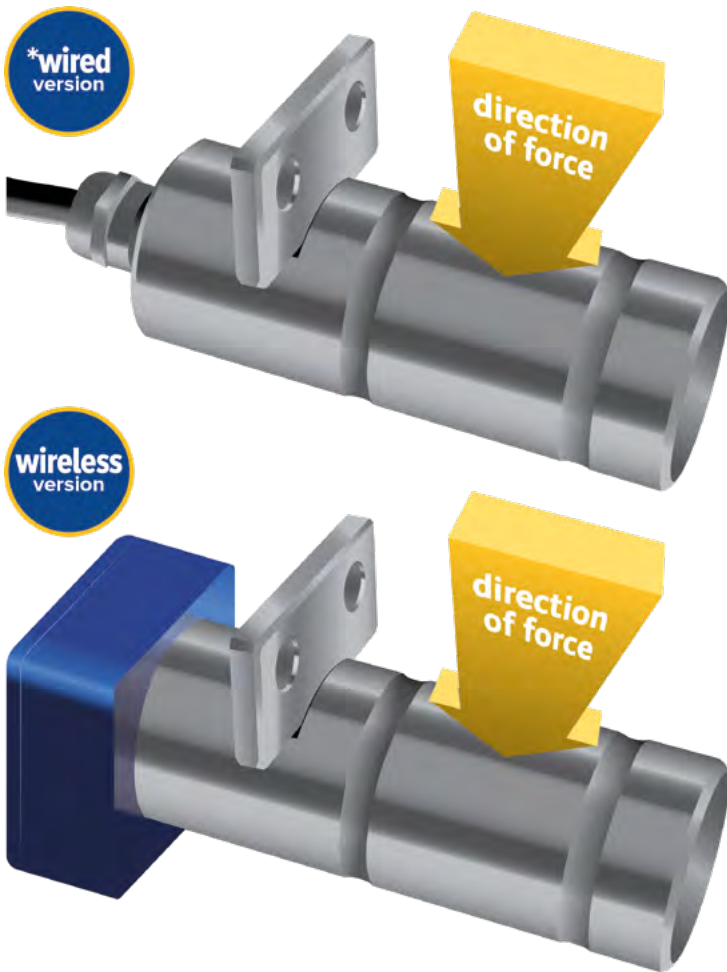

APPLICATIONS

- Marine tankers, offshore platforms
- Elevator and floor conveyor testing and certification
- Bearing blocks, pivots and shackles
- Cable laying equipment
- Rope, chain and brake anchors
- Bridge support cables
- Mooring lines
- Pulleys and sheaves
- Crane cables
- Hoisting gear
- Winches
- Design validated by F.E.A.

Please note: Please advise cable configuration on order - Radial or Axial pin exit.
If you require a Loadpin to a particular size and design, download Straightpoint's Loadpin questionnaire and return, POA.
straightpoint.com/loadpin.html

The Crosby Straightpoint range of Load Measurement Pins (LMP's) are designed for use in applications where an end of line load cell cannot be used, meaning an integrated solution is required.

Often a customised solution, they are manufactured from high tensile stainless steel and are normally supplied complete with an anti-rotation plate as a cabled or wireless solution.

Built to withstand the harshest environments in industries such as marine and offshore oil and gas, they are suitable for use in exposed situations and can also be supplied to withstand immersion in seawater at extreme depths.

Crosby Straightpoint Loadpins are typically connected to Straightpoint's Handheld plus, or may be supplied with a vast array of output formats. These include mV/V, 4-20mA output, utilising the ASCII, MODBUS RTU and CAN-BUS protocols or an analogue output such as 4-20mA for PLC integration. All are also supplied with a 10 metre or 32ft cable as standard, however, usable cable length varies greatly with lengths available to 1500 metres or 4900ft, depending on output format.

Please email your enquiry to:
sales.sp@straightpoint.com

Also available with hazardous area approval. Zones 0, 1 & 2



ATEX / IECEX

Ex ia II CT4 Ga

Certification numbers:
LP ATEX

IECEX SIR 16.0041X / SIRA 16ATEX2108X / CSAE 22UKEX1266X

SW-HHP ATEX

IECEX SIR 15.0072X / SIRA 15ATEX2196X / CSAE 22UKEX1267X

Add 'ATEX' to the part number
when ordering ATEX/IECEX products.
For example: LP500KG-ATEX

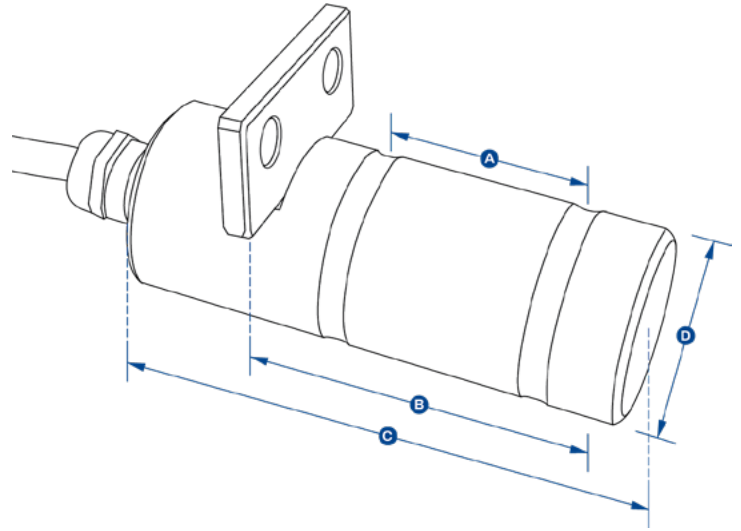

SP Model	LP500KG	LP1T	LP2.5T	LP3.5T	LP6.5T	LP15T	LP25T	LP50T	LP100T	LP250T	LP500T	LP750T	LP1000T	LP1500T
Crosby Part	2789276	2789277	2789278	2789279	2789280	2789281	2789282	2789283	2789284	2789285	2789286	2789287	2789288	2789289
Capacity	500 kg 1,100 lb	1,000 kg 2,200 lb	2.5 te 5,500 lb	3.5 te 7,700 lb	6.5 te 14,000 lb	15 te 33,000 lb	25 te 55,000 lb	50 te 110,000 lb	100te 220,000 lb	250 te 550,000 lb	500te 110,0000lb	750 te 165,0000 lb	1,000 te 220,0000 lb	1,500 te 330,0000 lb
Resolution	0.2 kg 0.5 lb	0.5 kg 1 lb	0.001 te 2 lb	0.001 te 2 lb	0.002 te 5 lb	0.002 te 5 lb	0.005 te 10 lb	0.01te 20 lb	0.05 te 100 lb	0.1 te 200 lb	0.2te 500lb	0.2 te 500 lb	0.5 te 1,000 lb	0.5 te 1000 lb
Weight	0.9 kg 0.4 lb	1 kg 0.5 lb	1.2 kg 0.9 lb	1.4 kg 1.3 lb	2 kg 2.6 lb	3.1kg 5 lb	5.6 kg 10.3 lb	8.6 kg 18 lb	11.8 kg 24 lb	29.8 kg 64 lb	79.2kg 172lb	146 kg 319 lb	275 kg 603 lb	389 kg 854 lb
Units	te, lb, kg, kN													
Protection	IP67 (IP68 available as option)													
Safety Factor	300% of SWL													
Operating Temp	-10 to +50 °C / 14 to 122°F													
Accuracy	+/-1% FS													
Dimension A	24 0.94	35 1.38	45 1.77	50 1.97	63 2.48	75 2.95	89 3.50	102 4.02	110 4.33	130 5.12	225 8.86	295 11.61	360 14.17	430 16.93
Dimension B	36 1.42	49 1.93	70 2.76	75 2.95	95 3.74	114 4.49	152 5.98	178 7.01	190 7.48	220 8.66	370 14.57	500 19.69	612 24.09	731 28.78
Dimension C	70 2.76	80 3.15	100 3.94	105 4.13	125 4.92	150 5.91	195 7.68	225 8.86	230 9.06	300 11.81	440 17.32	590 23.23	712 28.03	832 32.76
Dimension ØD	20 0.79	20 0.79	25 0.98	30 1.18	40 1.57	50 1.97	63 2.48	75 2.95	88 3.46	125 4.92	170 6.69	200 7.87	250 9.84	275 10.83

Loadblock plus

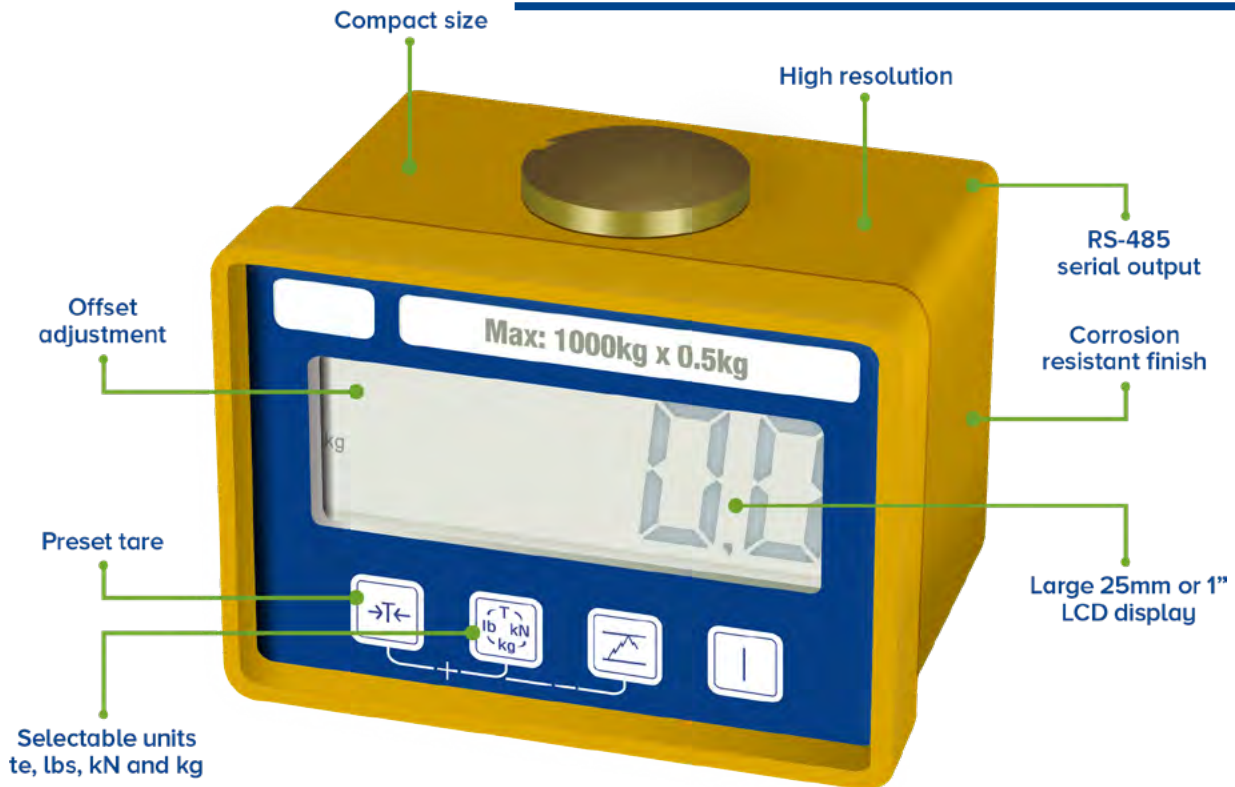

The Loadblock plus is a low capacity, self-indicating compression load cell, used in many testing and load monitoring applications worldwide.

The integral display eliminates the need for a separate display or cable assembly that can be easily damaged. Applications include the measurement of loads associated with the testing of hydraulic presses, cylinders or jacks.

This latest version of Straightpoint's Loadblock has advanced features and benefits that provide solutions for today's complicated load test, as well as force monitoring needs. Features include full function push button controls for tare, units of measure (lbs, kg, kN and tonnes), peak hold, pre-set tare, audible set-point alarm and an overload counter.

This crucial overload alarm counter is a requirement for many safety and quality control departments, as it keeps track of overload events. Should this occur, the load cell in question can be removed from service immediately, following the calibration-voiding overload event. It can then be sent out for proper testing and, if necessary, a recalibration can be done before it re-enters service.

The advanced microprocessor based electronics provide the Loadblock plus with high speed read rates (500/sec), extreme resistance to industrial level noise and unprecedented stability.

This high stability provides the Loadblock plus with 5,000+ divisions and the highest standard resolution of any self-indicating compression load cell on the market today.

The unit also features a RS-485 serial output port allowing for remote viewing with either the Handheld plus digital display/controller or Windows PC desktop controller data logging software.

FEATURES AND BENEFITS

- Large 25mm or 1" LCD Display
- High resolution
- 100Hz Peak hold
- Compact size
- Push button tare
- Preset tare
- RS485 port for connection to datalogging system
- Selectable units te, lbs, kN and kg

Optional connection to Straightpoint's
Handheld plus - **SP**
Crosby Part Nos. **HHP 2789459**

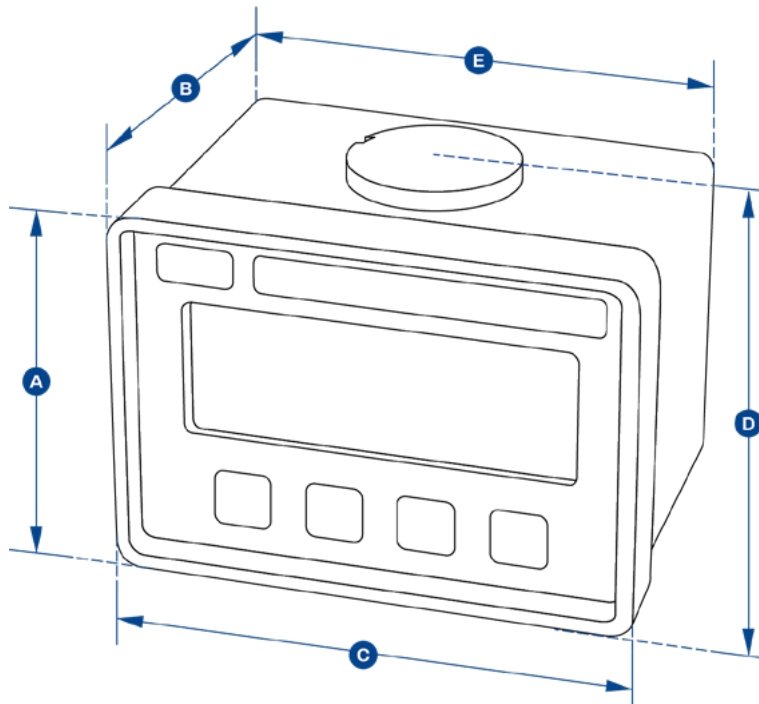

SP Model	LBP250KG	LBP500KG	LBP1T	LBP2T	LBP5T
Crosby Part	2789035	2789037	2789034	2789036	2789038
Capacity	250 kg	500 kg	1 te	2 te	5 te
	550 lb	1,100 lb	2,200 lb	4,400 lb	11,000 lb
Resolution	0.1 kg	0.2 kg	0.0005 te	0.001 te	0.001 te
	0.2 lb	0.5 lb	1 lb	2 lb	2 lb
Units	t, kg, kN, lb				
	lb, te, kN, kg				
Weight	900 g	900 g	900 g	1.5 kg	3.1 kg
	2 lb	2 lb	2 lb	3.3 lb	6.8 lb
Safety Factor	4:1	5:1	5:1	5:1	5:1
Protection	IP65 / NEMA4x				
Battery Type	9v PP3				
Battery Life	80hrs continuous				
Display Type	6 digit 25 mm LCD / 6 digit 1 in LCD				
Operating Temp	-10 to +50 °C / 14 to 122°F				
Accuracy	+/- 0.1% FS				
Dimension A	81	81	81	92	92
	3.19	3.19	3.19	3.62	3.62
Dimension B	81	81	81	117	136
	3.19	3.19	3.19	4.61	5.35
Dimension C	113	113		112	112
	4.45	4.45	4.45	4.41	4.41
Dimension D	90	90	90	104	115
	3.54	3.54	3.54	4.09	4.53
Dimension E	104	104	104	N/A	
	4.09	4.09	4.09		

Miniweigher plus



FEATURES AND BENEFITS

- Large 25mm or 1" LCD Display
- High Accuracy
- Selectable Units te, lbs, kN & kg
- High Resolution
- Compact Size
- Tare
- Preset Tare
- Lightweight
- Overload Counter
- 90dB Audible Set Point Alarm
- RS-485 Serial Output
- Corrosion-Resistant Finish

Optional connection to Straightpoint's Handheld plus - SP

Crosby Part Nos. **HHP 2789459**

This small and compact mini crane weigher scale will suit most lifting applications and is available in capacities from 100kg to 5t.

Worldwide, it is Straightpoint's most popular product and has been manufactured since 1987. The Miniweigher plus crane scale offers robust construction, high accuracy, compact size and extreme portability.

Utilised by utility companies on every continent, the Miniweigher plus crane scale is quite often mounted between a winch and a tripod. This mounting point allows for load monitoring to be integrated within the lift, ensuring safety levels during the lowering and raising of equipment and/or personnel are optimised. It has proven itself to be an indispensable tool for underground sewer, water, gas and utility vault access.

The Miniweigher plus features full function push button controls for tare, choice of units (lbs, kg, kN and tonnes), peak hold, preset tare, audible set-point alarm and an overload counter.

Straightpoint's advanced microprocessor based electronics provide the Miniweigher plus with high speed read rates, extreme resistance to industrial level noise and unprecedented stability. This high stability allows 5,000+ divisions and the highest standard resolution of any compact digital crane scale on the market today. The unit also features a RS-485 serial output providing added functionality and versatility.

In all, the lightweight design, corrosion-resistant finish, advanced electronics and full feature display have made the Miniweigher plus crane scale the only choice when looking for a compact, safe and accurate, crane scale.

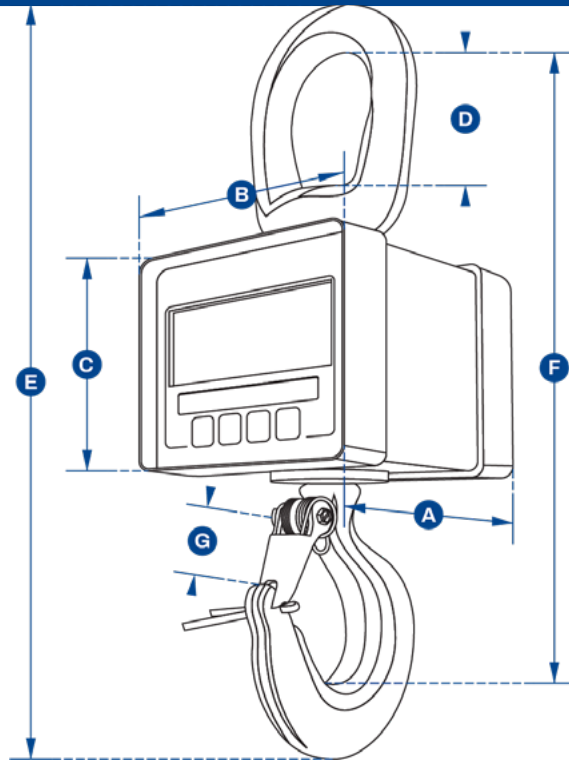

SP Model	MWP100KG	MWP250KG	MWP500KG	MWP1T	MWP2T	MWP5T
Crosby Part	2789055	2789057	2789059	2789056	2789058	2789060
Capacity	100 kg	250 kg	500 kg	1,000 kg	2 te	5 te
	220 lb	550 lb	1,100 lb	2,200 lb	4,400 lb	11,000 lb
Resolution	0.05 kg	0.1 kg	0.2 kg	0.5 kg	0.001 te	0.001 te
	0.1lb	0.2 lb	0.5 lb	1 lb	2 lb	2 lb
Units	t, kg, kN, lb					
Weight	1.5 kg	1.5 kg	1.5 kg	1.5 kg	3.1 kg	8.7 kg
	3.3 lb	3.3 lb	3.3 lb	3.3 lb	6.8 lb	19.2 lb
Safety Factor	10:1	5:1	5:1	5:1	5:1	5:1
Protection	IP65 / NEMA4x					
Battery Type	9v PP3					
Battery Life	80 hrs continuous					
Display Type	6 digit 25 mm LCD / 6 digit 1 in LCD					
Operating Temp	-10 to +50 °C / 14 to 122°F					
Accuracy	+/- 0.1% FS					
Dimension A	81	81	81	81	117	136
	3.19	3.19	3.19	3.19	4.61	5.35
Dimension B	112	112	112	112	112	112
	4.41	4.41	4.41	4.41	4.41	4.41
Dimension C	81	81	81	81	92	92
	3.19	3.19	3.19	3.19	3.62	3.62
Dimension D	33	33	33	33	43	62
	1.30	1.30	1.30	1.30	1.69	2.44
Dimension E	222	222	222	222	283	349
	8.74	8.74	8.74	8.74	11.14	13.74
Dimension F	183	183	183	183	238	286
	7.20	7.20	7.20	7.20	9.37	11.26
Dimension G	22	22	22	22	28	42
	0.87	0.87	0.87	0.87	1.10	1.65

Accreditations/Affiliations

Accreditations

Third party accreditation communicates to our customers and prospects that we comply with internationally recognised standards, building confidence whilst demonstrating our commitment to safety and quality.



ISO 9001 is the internationally recognised standard for the quality management of businesses. Our BSI accreditation means that we have been assessed against internationally recognised standards and operate to the highest levels of quality and service, providing further assurance to you that the certificate issued to us is credible.



Founded in 1906, the IEC (International Electrotechnical Commission) is the world's leading organisation for the preparation and publication of International Standards for all electrical, electronic and related technologies. These are known collectively as "electrotechnology".



Ex/IECEx approval on Crosby Straightpoint wireless product range, all connected to the first of its kind. Hand Control (SW-HHPEX), Radiolink plus (RLPEX), Loadshackle (WLSEX), Compression Load Cell (WNIEX), Loadpin (LPEX) and Running Line Tensiometer (TIMHEX).



All Crosby Straightpoint products are CE marked. CE is an abbreviation of the French phrase "Conformité Européene" which means "European Conformity". CE Marking on a product is our declaration that the product complies with the essential requirements of the relevant European health, safety and environmental protection legislation.



DNV GL enables organisations to advance the safety and sustainability of their business, providing them with classification, technical assurance, software and independent expert advisory services to the maritime, oil and gas and energy industries.

Affiliations



LEEA is established across the globe as the respected and authoritative representative body for all those involved in the lifting industry worldwide, representing their members at the highest levels across a range of both public and private bodies. The association has played a key role in this specialised field for over 70 years, from training and standards setting through to health and safety, the provision of technical and legal advice, and the development of examination and licensing systems.



ASME is the leading international developer of codes and standards associated with the art, science, and practice of mechanical engineering. Starting with the first issuance of its legendary Boiler & Pressure Vessel Code in 1914, ASME's codes and standards have grown to nearly 600 offerings currently in print. These offerings cover a breadth of topics, including pressure technology, nuclear plants, elevators / escalators, construction, engineering design, standardisation, and performance testing.



AWRF was formed in 1975 and incorporated the following year by a group of concerned businessmen who felt there was a need for sling fabricators and special rigging components manufacturers to join together to form a trade association. Originally created by representatives from nine companies in the United States, in two decades the organisation grew to concentrate on the needs of over 400 member companies worldwide.



SC&RA is an international trade association of nearly 1,300 member companies from 43 nations. Members are involved in specialised transportation, machinery moving and erecting, industrial maintenance, millwrighting, crane and rigging operations, manufacturing and rental. It helps run more efficient and safer businesses by monitoring and affecting pending legislation and regulatory policies at the state and national levels; researching and reporting on safety concerns and best business practices.



Construction

Tower cranes weighing materials with a digital dynamometer, using compression load cells to monitor piling loads, testing of reinforced steelworks or real-time monitoring of building load distribution are all applications where Crosby Straightpoint can offer a load monitoring solution. Crosby Straightpoint's range of wireless tension and compression load cells connected to our impressive range of handheld displays or multi Load cell data logging or centre of gravity software are used throughout the worldwide construction industry on a daily basis.

Logistics

From simple logistics and shipping weighing to measuring forces on mooring tension lines, Crosby Straightpoint have a solution. Products are IP rated and constructed from marine-grade materials to ensure that they remain accurate, reliable and most importantly, safe for use. For weighing up to 5t the Miniweigher plus is the go-to compact crane scale for safe and accurate weighing. Crosby Straightpoint's bestselling Radiolink plus takes care of the heavier lifts, allowing the operator to safely stand at distance of 1000m or 3280 feet from the load.

Oil and Gas

In the oil and gas centres of Scotland, Scandinavia and the gulf states of the USA the Radiolink plus load cell, along with the new addition of the Radiolink Plus ATEX / IECEx, are the industry standard for weighing and dynamic load monitoring applications. For lower headroom applications our wireless load shackles are also the first choice for service trucks and riggers in the oilfields. A rugged handheld display with easy to change AA batteries, no external antennae and industry leading wireless range allow the operator to stand at a safe distance in the most hazardous areas up to zone 0.

Construction

Tower cranes weighing materials with a digital dynamometer, using compression load cells to monitor piling loads, testing of reinforced steelworks or real-time monitoring of building load distribution are all applications where Crosby Straightpoint can offer a load monitoring solution. Crosby Straightpoint's range of wireless tension and compression load cells connected to our impressive range of handheld displays or multi Load cell data logging or centre of gravity software are used throughout the worldwide construction industry on a daily basis.

Stage and Event Rigging

With safety in mind, Crosby Straightpoint has a range of stage and event rigging load cells. The load shackle, where headroom is limited, is specifically useful. Up to 126 load cells can be connected via Crosby Straightpoint's INSIGHT software for more complex applications.

Proof Load Testing

Load testing with water bags, other weights or fixed load points are ideal applications for the Straightpoint range of load cells. Crosby Straightpoint's Radiolink plus, Wireless shackle load cells or compression load cells, used in parallel with the INSIGHT software proof test module, testing can be performed at a safe distance. All dynamic and static forces are logged onto a test certificate for later analysis and client approval.

Wind Energy

To keep up with this rising demand, in wind farms, the number of people and equipment involved has also jumped up to match the expansion's pace. Crosby Straightpoint can supply load monitoring solutions up to a 1000t. The diversity of our solutions, on offer, cover many parts of the construction process. The range of wireless load cells is ideal for measuring the load for installation and maintenance on and offshore.

Heavy Lifting

When large industrial items such as absorbers, generators, turbines, reactors, boilers, towers, locomotives, boats, military equipment or offshore industry parts such as oil rigs and production platforms have to be moved on short lead times, heavy lift companies need large capacity load cells. For many heavy lift projects there is an absence of standardisation which requires an individual transport planning and with a range of tension and compression load cells and software including an ISO19901 compliant centre of gravity software package in stock and ready to ship

Towage and Salvage

Load monitoring is essential in the marine, towing and mooring industries as ever changing sea states create unknown and variable loads. Load monitoring is essential in the marine, towing and mooring industries as ever changing sea states create unknown and variable loads. Crosby Straightpoint have developed a new product for lashing and tie downs, ChainSafe, which can be attached to any chain and fitted with an extensive range of products from The Crosby Group.

Wind Energy

To keep up with this rising demand, in wind farms, the number of people and equipment involved has also jumped up to match the expansion's pace. Crosby Straightpoint can supply load monitoring solutions up to a 1000t. The diversity of our solutions, on offer, cover many parts of the construction process. The range of wireless load cells is ideal for measuring the load for installation and maintenance on and offshore.

Utilities

Utility companies across the globe all use Straightpoint products. Power line tensioning, pump station maintenance and critical lift monitoring are all applications for Straightpoint's range of load cells. No utility service truck is complete without a Straightpoint product in its kit.

Marine

For offshore, subsea and general marine applications Crosby Straightpoint have a range of Running Line Dynamometers, Loadshackles and Subsea load cells, IP68 rated. Crosby Straightpoint's Loadshackles and Loadpin products can be manufactured for subsea use if required and output options such as 4-20mA or Modbus. For mooring, cable laying and winch applications, the TIMH running line dynamometer can be used to measure both tension and line out.



Crosby | BLOKCAM

Crosby | BLOKCAM

Crosby | BLOKCAM

Blok511 - Camera 1 27.10.2022 13:13:28

Blok512 - Camera 1 27.10.2022 13:13:30

Blok513 - Camera 2 27.10.2022 13:13:30

Crosby

IMPROVE SAFETY & PRODUCTIVITY ON YOUR NEXT LIFT

Wireless cameras & audio-visual warning systems designed specifically for crane blocks & boom tips

- Reduce hazards
- Avoid impacts & collisions
- Confirm load security
- Optimize lifting times
- Improve job site communication
- Return on the bottom line



BLOKCAM X3L



BLOKCAM M3L



BLOKALERT

Grosby | **BLOKCAM**[®]



Kito Crosby is the global leader of the lifting and securement industry it pioneered, and for which it continues to set the quality standard. With global engineering, manufacturing, distribution, and operations, the company provides a broad range of products and solutions for the most demanding applications. Kito Crosby's people, products, solutions, and services have innovated the lifting and securement industry for more than 260 years.

Together we lift and secure the world today, for a safer, stronger, and more productive tomorrow. Our iconic brands include Kito, Crosby, Harrington, Gunnebo Industries, and Peerless.

kitocrosby.com



123 Proxima Park, Houghton Avenue, Waterlooville, Hampshire, PO7 3DU, UK · Tel: +44 (0)2392 484491
Industriepark B26, 2220 Heist-op-den-Berg, Belgium · Tel: 0032 15 75 71 25
2801 Dawson Road, Tulsa, OK 74110 · USA · Tel: +1 (918) 834-4611

straightpoint.com · sales.sp@kitocrosby.com

